

EcoStar™

by **HAYWARD®**
Owner's Manual

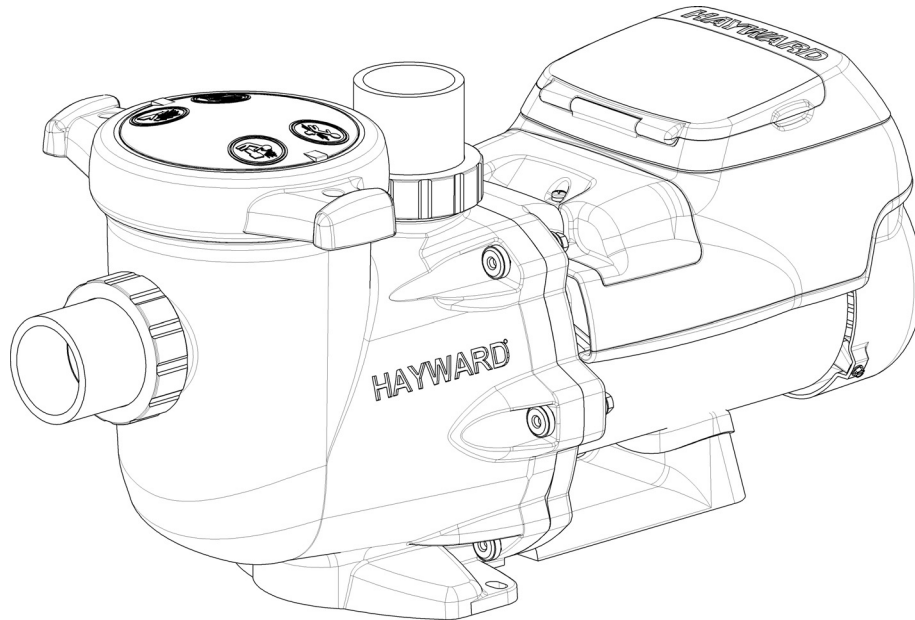

**Models SP3400VSP, SP3400VSPVR
EcoStar Variable Speed Pump**

Hayward EcoStar is the industry's most energy efficient variable speed pump. The totally enclosed, permanent magnet motor combined with its advanced hydraulic design provides unparalleled energy savings. EcoStar is easily installed either as a programmable stand-alone pump or with a Hayward or third party controller and features an easy-to-use digital control interface that can be mounted in four different positions on the pump or removed and mounted on the wall for total user convenience. The EcoStar SVRS model provides an added layer of protection from suction entrapment without additional devices, plumbing or wiring.

NOTE - To prevent potential injury and to avoid unnecessary service calls, read this manual carefully and completely.

SAVE THIS INSTRUCTION MANUAL

Table of Contents

1.	IMPORTANT SAFETY INSTRUCTIONS	4
2.	General Information	7
2.1.	Introduction	7
2.2.	Primary Features	7
2.3.	Product Dimensions	7
3.	Installation and Wiring.....	7
3.1.	Pump Location	7
3.2.	Pump Mounting	8
3.3.	Pipe Sizing Chart	8
3.4.	Plumbing	8
3.5.	Electrical	8
3.6.	Electrical Specs	9
3.7.	Voltage	9
3.8.	Grounding and Bonding	9
3.9.	Wiring	9
3.10.	Remote Control Wiring/Operation	10
3.11.	SVRS Notes (Only applicable to SP3400VSPVR)	10
3.12.	Digital Control Interface Orientation	11
3.13.	Interface Wall Mounting	11
3.14.	Installation Notes	13
4.	Wiring Diagrams	13
4.1.	Input Power/Motor Wiring	13
4.2.	Wall Mounted Digital Control Interface Wiring	13
4.3.	Hayward Control Wiring	14
4.4.	External Relay Speed Control Wiring	14
4.5.	Remote Stop Wiring	14
5.	Startup & Operation.....	15
5.1.	Prior to Start-Up	15
5.2.	Starting/Priming the Pump	15
5.3.	User Interface Summary	16
5.4.	Menu Outline	16
5.5.	Initial startup	17
5.6.	Configuration Menu	18
5.7.	Timer Menu	19
5.8.	Preset Speed Setup Menu	20
5.9.	Diagnostic Menu	20
5.10.	Stop/Resume	21
5.11.	Quick Clean	21
5.12.	Remote Stop	22
6.	Maintenance	22
7.	Storage / Winterization	22
7.1.	Storing Pump For Winterization	23
8.	Shaft Seal Change Instructions	23
8.1.	Removing the Motor Assembly	23

USE ONLY HAYWARD GENUINE REPLACEMENT PARTS

8.2. Removing the Impeller	23
8.3. Removing the Ceramic Seat	24
8.4. Seal Installation	24
8.5. Replacing the Impeller and Diffuser	24
8.6. Replacing the Motor Assembly	24
9. Replacement Parts.....	26
9.1. Parts Diagram	26
9.2. Parts Listing	26
10. Energy Efficiency Overview.....	27
11. Troubleshooting	28
11.1. General Problems	28
11.2. Error Codes	29
12. Warranty.....	30
13. Product Registration	31

1. IMPORTANT SAFETY INSTRUCTIONS

Before installing or servicing this electrical equipment, turn power supply OFF.

Basic safety precautions should always be followed, including the following: Failure to follow instructions may result in injury.

 This is the safety-alert symbol. When you see this symbol on your pump or in this manual, look for one of the following signal words, and be alert to the potential for personal injury.

 **WARNING** warns about hazards that **could** cause serious personal injury, death or major property damage and if ignored presents a potential hazard.

 **CAUTION** warns about hazards that **will** or **can** cause minor or moderate personal injury and/or property damage and if ignored presents a potential hazard. It can also make consumers aware of actions that are unpredictable and unsafe.

The **NOTICE** label indicates special instructions that are important but not related to hazards.



 **WARNING** – Read and follow all instructions in this owner’s manual and on the equipment. Failure to follow instructions can cause severe injury and/or death.

 **WARNING** – This product should be installed and serviced only by a qualified professional.

 **CAUTION** – All electrical wiring **MUST** be in conformance with all applicable local codes, regulations, and the National Electric Code (NEC).

USE OF NON-HAYWARD REPLACEMENT PARTS VOIDS WARRANTY.

ATTENTION INSTALLER - THIS MANUAL CONTAINS IMPORTANT INFORMATION ABOUT THE INSTALLATION, OPERATION, AND SAFE USE OF THIS VARIABLE SPEED PUMP THAT MUST BE FURNISHED TO THE END USER OF THIS PRODUCT. FAILURE TO READ AND FOLLOW ALL INSTRUCTIONS COULD RESULT IN SERIOUS INJURY.

 **WARNING** – To reduce risk of injury, do not permit children to use or climb on this product. Closely supervise children at all times. Components such as the filtration system, pumps, and heaters must be positioned to prevent children from using them as a means of access to the pool.

 **CAUTION** – This pump is intended for use on permanently installed swimming pools and may also be used with hot tubs and spas if so marked. Do NOT use with storable pools. A permanently installed pool is constructed in or on the ground or in a building such that it cannot be readily disassembled for storage. A storable pool is constructed so that it is capable of being readily disassembled for storage and reassembled to its original integrity. Though this product is designed for outdoor use, it is strongly advised to protect the electrical components from the weather. Select a well-drained area, one that will not flood when it rains. It requires free circulation of air for cooling. Do not install in a damp or non-ventilated location. If installed within an outer enclosure or beneath the skirt of a hot tub or spa, adequate ventilation and free circulation of air must be provided to prevent overheating of the motor.

USE ONLY HAYWARD GENUINE REPLACEMENT PARTS

 **WARNING** – Pool and spa components (seals, gaskets, etc.) have a finite life. All components should be inspected frequently and replaced at least every ten years, or if found to be damaged, broken, cracked, missing, or not securely attached.



 **WARNING** – **Risk of Electric Shock.** All electrical wiring **MUST** be in conformance with applicable local codes, regulations, and the National Electric Code (NEC). Hazardous voltage can shock, burn, and cause death or serious property damage. To reduce the risk of electric shock, do **NOT** use an extension cord to connect unit to electric supply. Provide a properly located electrical receptacle. Before working on pump or motor, turn off power supply to the pump.

 **WARNING** – To reduce the risk of electric shock replace damaged wiring immediately. Locate conduit to prevent abuse from lawn mowers, hedge trimmers and other equipment.

 **WARNING** – **Risk of Electric Shock.** In accordance with the National Electric Code (NEC), connect only to a branch circuit protected by a ground-fault circuit-interrupter (GFCI). Contact a qualified electrician if you cannot verify that the circuit is protected by a GFCI. The unit must be connected only to a supply circuit that is protected by a ground-fault circuit-interrupter (GFCI). Such a GFCI should be provided by the installer and should be tested on a routine basis. To test the GFCI, push the test circuit button. The GFCI should interrupt power. Push the reset button. Power should be restored. If the GFCI fails to operate in this manner, the GFCI is defective. If the GFCI interrupts power to the pump without the test button being pushed, a ground current is flowing, indicating the possibility of an electric shock. Do not use this pump. Disconnect the pump and have the problem corrected by a qualified service representative before using.

 **WARNING** – Failure to bond pump to pool structure will increase risk for electrocution and could result in injury or death. To reduce the risk of electric shock, see installation instructions and consult a professional electrician on how to bond pump. Also, contact a licensed electrician for information on local electrical codes for bonding requirements.

Notes to electrician: Use a solid copper conductor, size 8 or larger. Run a continuous wire from external bonding lug to reinforcing rod or mesh. Connect a No. 8 AWG (8.4 mm²) [No. 6 AWG (13.3 mm²) for Canada] solid copper bonding wire to the pressure wire connector provided on the pump housing and to all metal parts of swimming pool, spa, or hot tub, and to all electrical equipment, metal piping (except gas piping), and conduit within 5 ft. (1.5 m) of inside walls of swimming pool, spa, or hot tub. **IMPORTANT** - Reference NEC codes for all wiring standards including, but not limited to, grounding, bonding and other general wiring procedures.

 **WARNING** – **Suction Entrapment Hazard.** Suction in suction outlets and/or suction outlet covers, which are damaged, broken, cracked, missing, or unsecured cause severe injury and/or death due to the following entrapment hazards (symbols complements of APSP):



Hair Entrapment - Hair can become entangled in suction outlet cover.



Limb Entrapment - A limb inserted into an opening of a suction outlet sump or suction outlet cover that is damaged, broken, cracked, missing, or not securely attached can result in a mechanical bind or swelling of the limb.



Body Suction Entrapment - A differential pressure applied to a large portion of the body or limbs can result in an entrapment.



Evisceration/ Disembowelment - A negative pressure applied directly to the intestines through an unprotected suction outlet sump or suction outlet cover which is damaged, broken, cracked, missing, or unsecured can result in evisceration/disembowelment.

Mechanical Entrapment - There is potential for jewelry, swimsuits, hair decorations, fingers, toes, or knuckles to be caught in an opening of a suction outlet cover resulting in mechanical entrapment.

Note: See section 3.11 for SVRS-related notes.

USE ONLY HAYWARD GENUINE REPLACEMENT PARTS

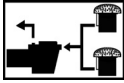
 **WARNING** – To Reduce the risk of Entrapment Hazards:

- When outlets are small enough to be blocked by a person, a minimum of two functioning suction outlets per pump must be installed. Suction outlets in the same plane (i.e. floor or wall), must be installed a minimum of three feet (3') [0.91 meter] apart, as measured from near point to near point.
- Dual suction fittings shall be placed in such locations and distances to avoid “dual blockage” by a user.
- Dual suction fittings shall not be located on seating areas or on the backrest for such seating areas.
- The maximum system flow rate shall not exceed the values shown in the “Pipe Sizing Chart” found in section 3.3 below.
- Never use pool or spa if any suction outlet component is damaged, broken, cracked, missing, or not securely attached.
- Replace damaged, broken, cracked, missing, or not securely attached suction outlet components immediately.
- In addition to two or more suction outlets per pump installed in accordance with latest APSP standards and CPSC guidelines, follow all national, state, and local codes applicable.
- Installation of a vacuum release or vent system, which relieves entrapping suction, is recommended.





 **WARNING – Hazardous Pressure.** Pool and spa water circulation systems operate under hazardous pressure during start-up, normal operation, and after pump shut-off. Stand clear of circulation system equipment during pump start-up. Failure to follow safety and operation instructions could result in violent separation of the pump housing and cover due to pressure in the system, which could cause property damage, severe personal injury, or death. Before servicing pool and spa water circulation system, all system and pump controls must be in off position and filter manual air relief valve must be in open position. Before starting pump, all system valves must be set in a position to allow system water to return back to the pool. Do not change filter control valve position while pump is running. Before starting pump, fully open filter manual air relief valve. Do not close filter manual air relief valve until a steady stream of water (not air or air and water mix) is discharged from the valve. All suction and discharge valves **MUST** be OPEN when starting the circulation system. Failure to do so could result in severe personal injury and/or property damage.



 **WARNING – Separation Hazard.** Failure to follow safety and operation instructions could result in violent separation of pump components. Strainer cover must be properly secured to pump housing with strainer cover lock ring. Before servicing pool and spa circulation system, all system and pump controls must be in off position and filter manual air relief valve must be in open position. Do not operate pool and spa circulation system if a system component is not assembled properly, damaged, or missing. Do not operate pool and spa circulation system unless filter manual air relief valve body is in locked position in filter upper body. All suction and discharge valves **MUST** be OPEN when starting the circulation system. Failure to do so could result in severe personal injury and/or property damage.

 **WARNING** – Never operate the circulation system at more than 50 PSI maximum.

 **WARNING – Fire and burn hazard.** Motors operate at high temperatures and if they are not properly isolated from any flammable structures or foreign debris they can cause fires, which may cause severe personal injury or death. It is also necessary to allow the motor to cool for at least 20 minutes prior to maintenance to minimize the risk for burns.

 **WARNING** – Failure to install according to defined instructions may result in severe personal injury or death.

2. General Information

2.1. Introduction

This manual contains information for the proper installation and operation of the Hayward EcoStar Variable Speed Pump. The instructions in this manual **MUST** be followed precisely. Failure to install according to defined instructions will void warranty.

2.2. Primary Features

- Totally enclosed, permanent magnet motor
- Advanced hydraulic design
- SVRS model available compliant to ASME 112.19.17 Safety Vacuum Release System (SVRS) standard
- Fully programmable with a self-contained 24-hour clock and up to 8 custom speed and timer functions
- For enhanced pool management, can be controlled by Hayward or third party pool and spa control platforms, without the need for additional accessories
- Digital control interface that can be mounted in four different positions on the pump or removed and mounted on the wall (wall-mount kit included)
- No-rib, extra large basket design ensures easy debris removal and extends time between cleanings
- Motor drive includes built-in protection for high temperatures and voltage fluctuations. Drive is also designed to withstand temperatures below freezing without issue.

2.3. Product Dimensions

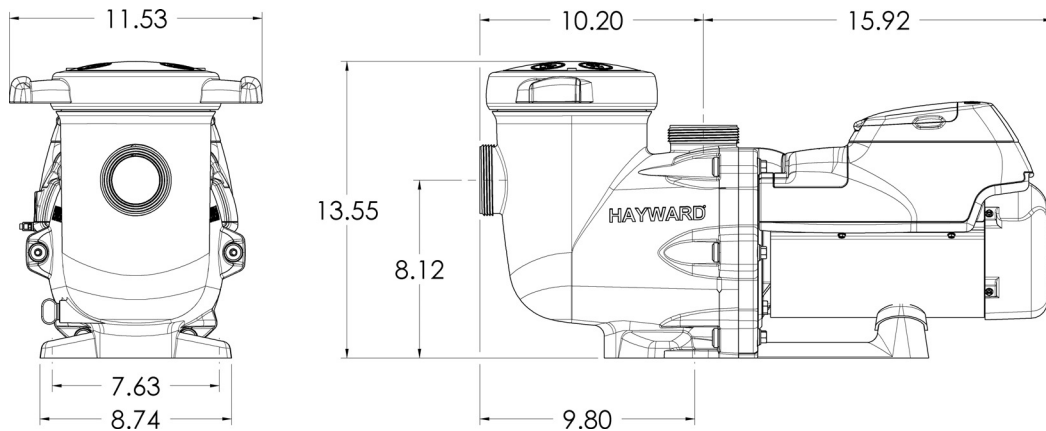

3. Installation and Wiring

⚠ WARNING – This product should be installed and serviced only by a qualified professional.

3.1. Pump Location

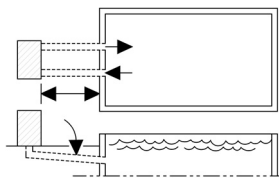

Locate pump as close to pool as practical and run suction lines as direct as possible to reduce friction loss. Suction lines should have continuous slope upward from lowest point in line. Joints must be tight (but not over-tightened). Suction line diameter must equal or be larger than the discharge line diameter.

Though the pump is designed for outdoor use, it is advised to place pump and filter in the shade to shield them from continuous direct heat. Select a well-drained area that will not flood when it rains. Do NOT install pump and filter in a damp or non-ventilated location. Keep motor clean. Pump motors require free circulation of air for cooling.

USE ONLY HAYWARD GENUINE REPLACEMENT PARTS

3.2. Pump Mounting

Install pump on a level concrete slab or other rigid base to meet all local and national codes. Secure pump to base with screws or bolts to further reduce vibration and stress on pipe or hose joints. The base must be level, rigid, and vibration free.

Pump mount must:

- Allow pump inlet height to be as close to water level as possible.
- Allow use of short, direct suction pipe (to reduce friction losses).
- Allow for valves in suction and discharge piping.
- Be protected from excess moisture and flooding.
- Allow adequate access for servicing pump and piping.

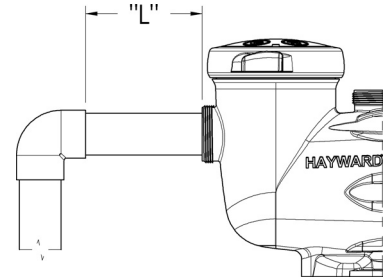

3.3. Pipe Sizing Chart

MAXIMUM RECOMMENDED SYSTEM FLOW RATE BY PIPE SIZE		
Pipe Size in. [mm]	Maximum Flow Rate GPM [LPM]	Minimum Suction Pipe Length* in. [mm]
1" [32]	20 [75]	5" [127]
1 ¼" [40]	30 [110]	6 ¼" [159]
1 ½" [50]	45 [170]	7 ½" [190]
2" [63]	80 [300]	10" [254]
2 ½" [75]	110 [415]	12 ½" [317]
3" [90]	160 [600]	15" [381]

* **Note:** It is recommended that a minimum length of straight piping (shown as "L" in above diagram), equivalent to 5 pipe size diameters, be used between the pump suction inlet and any plumbing fittings (elbows, valves, etc.).



WARNING – Hazardous Pressure. Pumps, filters, and other equipment/ components of a swimming pool filtration system operate under pressure. Incorrectly installed and/or improperly tested filtration equipment and/or components may fail resulting in severe personal injury or death.

3.4. Plumbing

1. Use Teflon tape to seal threaded connections on molded plastic components. All plastic fittings must be new or thoroughly cleaned before use. **NOTE - Do NOT use Plumber's Pipe Dope** as it may cause cracking of the plastic components. When applying Teflon tape to plastic threads, wrap the entire threaded portion of the male fitting with one to two layers of tape. Wind the tape clockwise as you face the open end of the fitting, beginning at the end of the fitting. The pump suction and outlet ports have molded-in thread stops. Do NOT attempt to force hose connector fitting past this stop. It is only necessary to tighten fittings enough to prevent leakage. Tighten fitting by hand and then use a tool to engage fitting an additional 1 ½ turns. Use care when using Teflon tape as friction is reduced considerably; do NOT over-tighten fitting or you may cause damage. If leaks occur, remove connector, clean off old Teflon tape, re-wrap with one to two additional layers of Teflon tape, and re-install connector.
2. Fittings (elbows, tees, valves, etc.) restrict flow. For better efficiency, use the fewest possible fittings. Avoid fittings that could cause an air trap. Pool and spa fittings **MUST** conform to the International Association of Plumbing and Mechanical Officials (IAPMO) standards.

3.5. Electrical



WARNING – All electrical wiring **MUST** conform to local codes, regulations, and the National Electric Code (NEC).

USE ONLY HAYWARD GENUINE REPLACEMENT PARTS

⚠ WARNING – Ground and bond pump before connecting to electrical power supply. Failure to ground and bond pump can cause serious or fatal electrical shock hazard. Do NOT ground to a gas supply line. To avoid dangerous or fatal electrical shock, turn OFF power to pump before working on electrical connections. Fire Hazard - match supply voltage to pump nameplate voltage. Insure that the electrical supply available agrees with the pump's voltage, phase, and cycle, and that the wire size is adequate for the amps rating and distance from the power source. Use copper conductors only.

3.6. Electrical Specs

1. Voltage: 230VAC, 60Hz, Single Phase
2. Amps: 10.9
3. Speed Range: 600-3450 rpm (1000-3450 rpm for SP3400VSPVR)

Use copper conductors only. For indoor & outdoor use. A disconnecting means located within sight of this control, and at least 5 ft. from the inside wall of the pool, spa, or hot tub, must be provided.

3.7. Voltage

Voltage at pump MUST NOT be more than 10% above or below nameplate rated voltage, or components may overheat, causing overload tripping and reduced component life. If voltage is less than 90% or more than 110% of rated voltage when pump is running at full load, consult the power company.

3.8. Grounding and Bonding

1. Install, ground, bond, and wire pump in accordance with local or national electrical code requirements.
2. Permanently ground pump. Use green ground terminal provided under access plate; use size and type wire required by code. Connect ground terminal to electrical service ground.
3. Bond pump to pool structure. Bonding will connect all metal parts within and around the pool with a continuous wire. Bonding reduces the risk of a current passing between bonded metal objects, which could potentially cause electrical shock if grounded or shorted. Reference NEC codes for all wiring standards including, but not limited to, grounding, bonding and general wiring procedures.
4. Use a solid copper conductor, size 8 or larger. Run wire from external bonding lug to reinforcing rod or mesh. Connect a No. 8 AWG (8.4 mm²) [No. 6 AWG (13.3 mm²) for Canada] solid copper bonding wire to the pressure wire connector provided on the motor housing and to all metal parts of swimming pool, spa, or hot tub, and to all electrical equipment, metal piping (except gas piping), and conduit within 5 ft. (1.5 m) of inside walls of swimming pool, spa, or hot tub.

3.9. Wiring

⚠ WARNING – All electrical wiring MUST conform to local codes, regulations, and the National Electric Code (NEC).

1. Pump MUST be permanently connected to circuit. If other lights or appliances are also on the same circuit, be sure to add their amp loads before calculating wire and circuit breaker sizes. Use the load circuit breaker as the Master On-Off switch.
2. If the EcoStar pump is being used to replace an existing pump that was controlled by a separate mechanical time clock, the EcoStar pump should be connected directly to the line power supply, bypassing the time clock. The time clock can then be used to power other equipment (such as a heater, heat pump, or booster pump) that requires the filter pump to be operating when used. If the time clock is used in this manner, it should be set to power the equipment during a time cycle when the EcoStar pump is operating at an appropriate flow rate to operate the other equipment, as defined by the timers set in the timers menu.

3.10. Remote Control Wiring/Operation

The EcoStar pump can communicate with and be controlled by Hayward Pro Logic, E-Command 4, and OnCommand pool controls. Consult Hayward pool control installation manual and Hayward Control Wiring diagram (section 4.3) for electrical connection details. Once installed, Remote Control Mode must be set to Standalone/Hayward in the pump Configuration Menu (see section 5.6), and COMM Bus Address must be set according to instructions provided in the Hayward pool control installation manual. It is best to leave the max/min allowed speeds in the pump configuration menu set to their factory defaults to prevent conflict with these settings in the Hayward pool control configuration menu.

The EcoStar pump can also be controlled from third party pool controls using relay contacts to select speeds set in the Timers Menu. Consult third party pool control installation manual and External Relay Speed Control Wiring diagram (section 4.4) for electrical connection details. Once installed, Remote Control Mode must be set to Relay Control in the pump Configuration Menu (see section 5.6). When Inputs 1-3 are activated via the pool control relays, timer speeds 1-8 are selected according to the table following section 5.6.11.

Preset Speeds 1-4, Quick Clean, and max-speed Prime Period are disabled when pump is remotely controlled.

3.11. SVRS Notes (Only applicable to SP3400VSPVR)

The Safety Vacuum Release System (SVRS) model is designed to provide an additional layer of protection against body suction entrapment. It complies with **ASME/ANSI A112.19.17-2002 SVRS** standard.

1. SVRS devices shall only be installed in conjunction with an **ASME A112.19.8** suction fitting, or a 12 in. x 12 in. (305 mm x 305 mm) drain grate or larger, or an approved channel drain system at each suction outlet or drain outlet.
2. Check valves and hydrostatic valves shall not be used in suction systems protected by SVRS devices.

 **WARNING** – The presence of a hydrostatic valve in the suction piping has been shown to prolong the high vacuum present at the drain, even though the drain was protected by an SVRS device.

3. All SVRS devices shall be factory set or field adjusted to site-specific hydraulic conditions. Once installed, the system shall be tested by simulating an entrapment event.
4. A ball, butterfly, or sliding gate valve shall be installed within 2 ft. (0.6 m) upstream from the SVRS (between the SVRS and the protected suction outlet), or a test mat shall be used to cover the suction outlet to simulate an entrapment event. There shall be three simulated entrapment tests conducted to verify proper adjustment and operation of the device.
5. One SVRS device shall be installed for each circulating pump plumbed directly to the suction outlet(s) without the use of valves that could isolate the SVRS device from the suction system.

3.12. Digital Control Interface Orientation

The Digital Control Interface can be rotated to any of four desired positions after installation by removing the two screws securing the interface to the motor drive, lifting the interface and rotating it to the desired position, and replacing the two screws in the new position. (Figure 3.12-1)

Figure 3.12-1

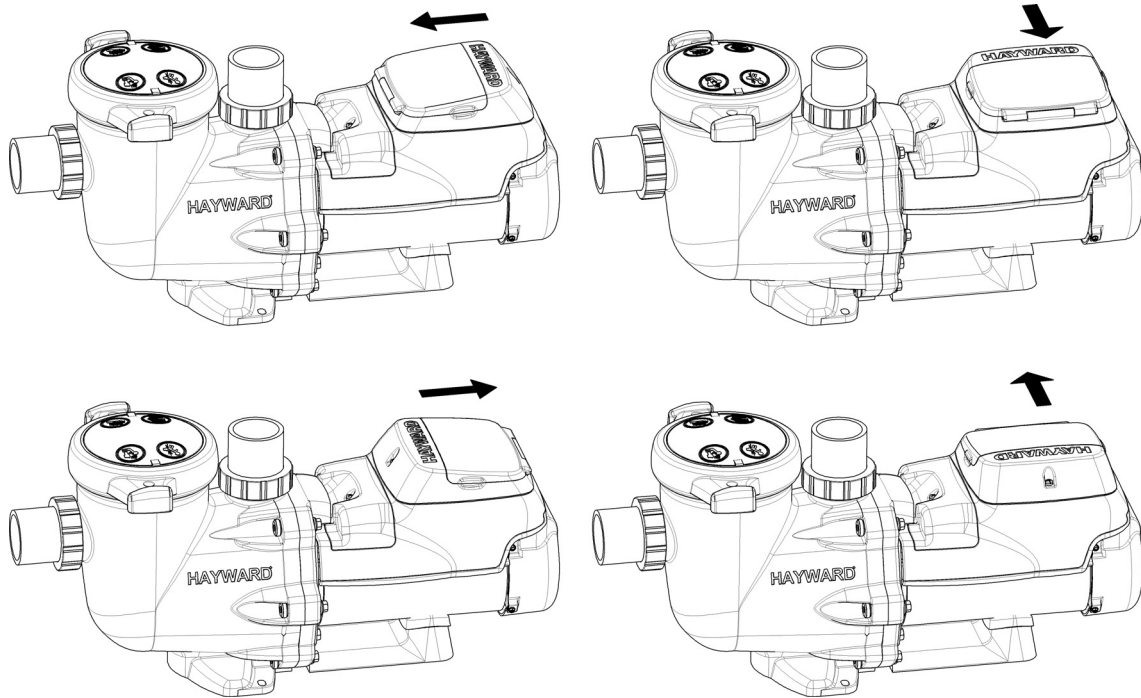

3.13. Interface Wall Mounting

The interface can also be wall mounted using the parts supplied in SP3200DRKIT using the following procedure.

1. TURN OFF THE ELECTRICAL POWER AT THE CIRCUIT BREAKER.
2. Remove the two screws securing the interface to the motor drive. (Figure 3.13-1)
3. Disconnect the short cable that extends out from the motor drive. (Figure 3.13-1)
4. Install the blank cover, SP3200DR9, on the motor drive in the desired orientation. This cover is important to protect internal electronics. (Figure 3.13-2)
5. Mount the wall mount plate, SP3200DR10, in the desired location. (Figure 3.13-3)
6. Connect the interface cable as shown in the Wall Mounted Digital Control Interface Wiring diagram shown in section 4.2 to the motor drive and interface PCB. The cable must be routed through the “DATA” conduit opening on the motor drive and through the slot provided on the backside of the wall mount plate, SP3200DR10. Cable used may be up to 500 feet in length. (Figure 3.13-3)
7. Mount the interface to the wall mount plate, SP3200DR10, using the two screws. (Figure 3.13-3)
8. Apply power to the system and resume normal operation.

The following diagrams help illustrate the interface wall mounting procedure.

Figure 3.13-1: Removing the Digital Control Interface for Wall Mounting

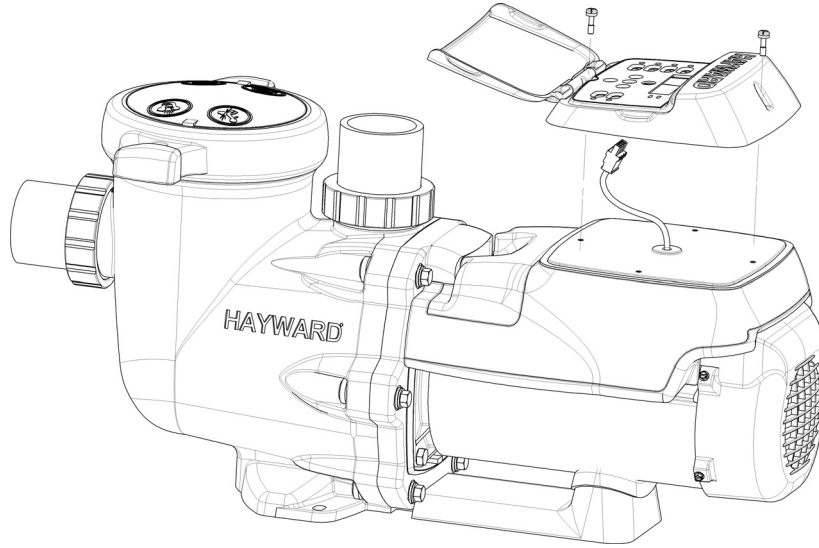

Figure 3.13-2: Adding the Blank Cover

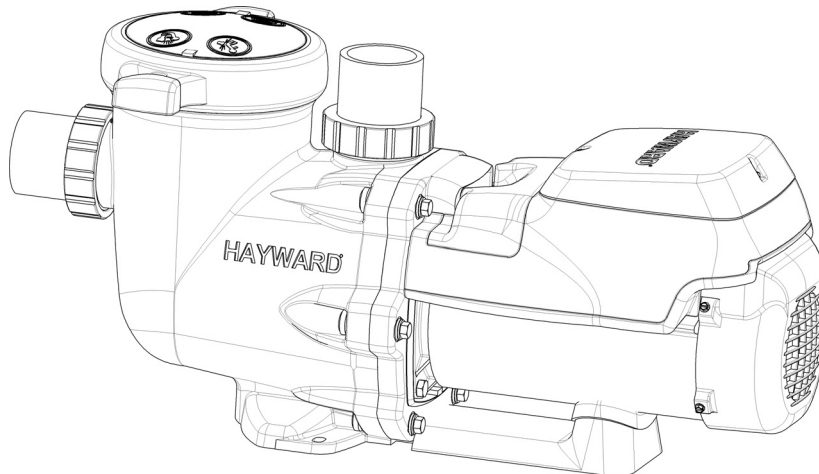
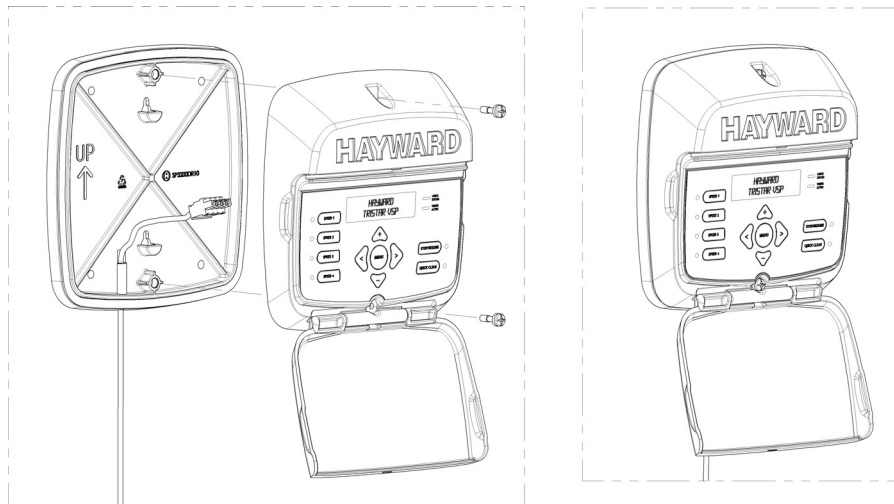

Figure 3.13-3: Wall Mounting the Interface



USE ONLY HAYWARD GENUINE REPLACEMENT PARTS

EcoStar Variable Speed Pump

IS3400VSP Rev-B

3.14. Installation Notes

1. **TURN OFF THE ELECTRICAL POWER AT THE CIRCUIT BREAKER.**
2. Remove the wiring access cover on the motor drive.
3. Connect 230VAC line power supply wiring to the terminal block and ground screw as shown in the Input Power/Motor Wiring diagram. Wiring must be routed through the conduit opening labeled “POWER”.
4. If the pump will be controlled using a Hayward pool control, connect a three-conductor cable as shown in the Hayward Control Wiring diagram. Wiring must be routed through the conduit opening labeled “DATA”.
5. If the pump will be controlled using relay contacts from an external control, connect the INP1-INP3 and 24VAC power out terminals to the external relays as shown. Wiring must be routed through the conduit opening labeled “DATA”. See section 5.6.11 for more details.
6. If the installation will use the remote stop feature of the drive, connect INP4 and 24VAC power out terminals to the remote stop switch as shown. Wiring must be routed through the conduit opening labeled “DATA”.
7. Connect the pump to the pool bonding system using 8AWG (6AWG for Canada) wire. A lug for bonding is provided on the outside of the drive enclosure.
8. After all electrical connections have been made, replace the wiring access cover on the motor drive and tighten the supplied screw.
9. Apply power to the system, and proceed to “Configuration Menu”, section 5.6.

4. Wiring Diagrams

4.1. Input Power/Motor Wiring

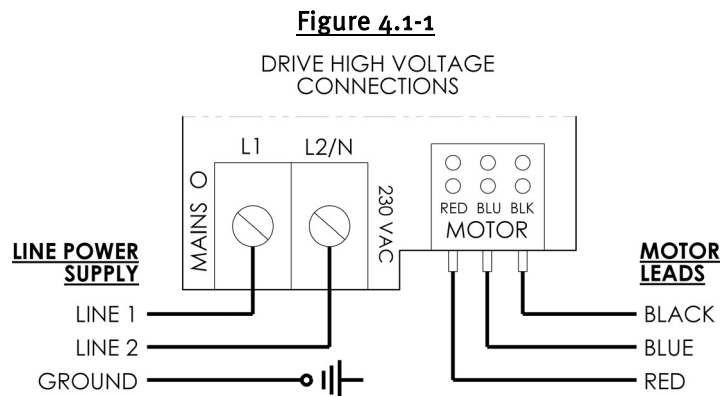

4.2. Wall Mounted Digital Control Interface Wiring

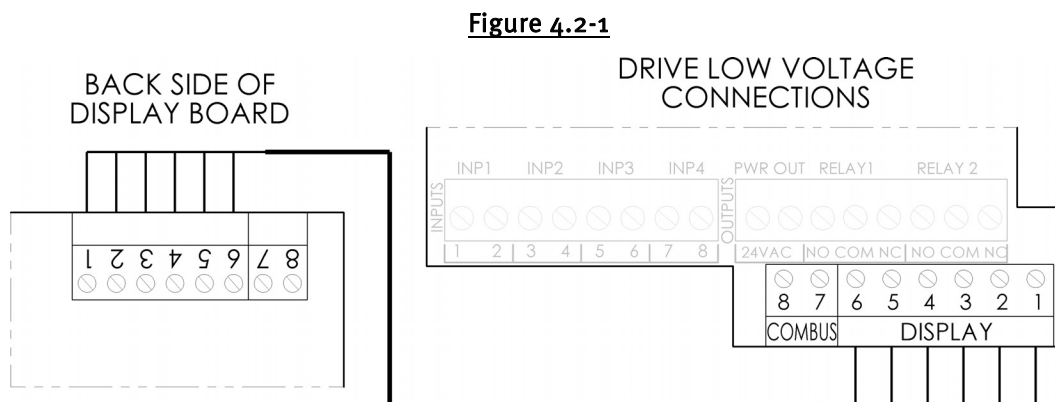

Note: Connection wire must be rated for a minimum of 350V. Wire used may be up to 500 feet in length.

USE ONLY HAYWARD GENUINE REPLACEMENT PARTS

4.3. Hayward Control Wiring

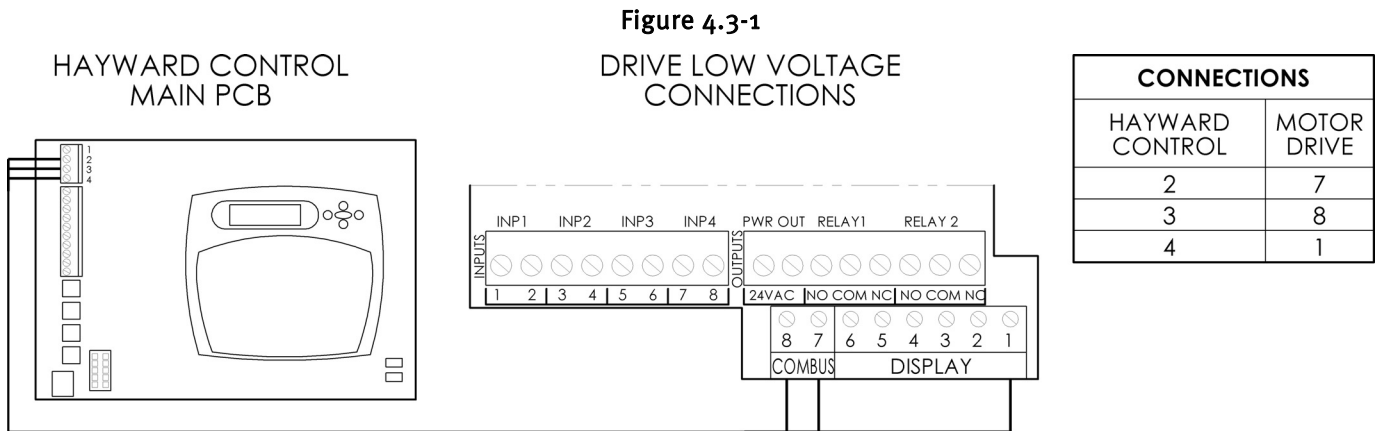

Note: Connection wire must be rated for a minimum of 350V. Wire used may be up to 500 feet in length.

4.4. External Relay Speed Control Wiring

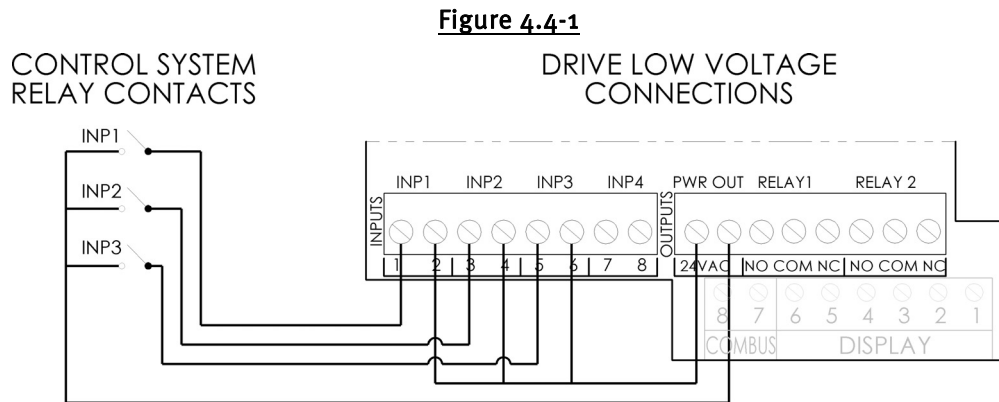

Note: Connection wire must be rated for a minimum of 350V. See section 5.6.11 for more details.

4.5. Remote Stop Wiring

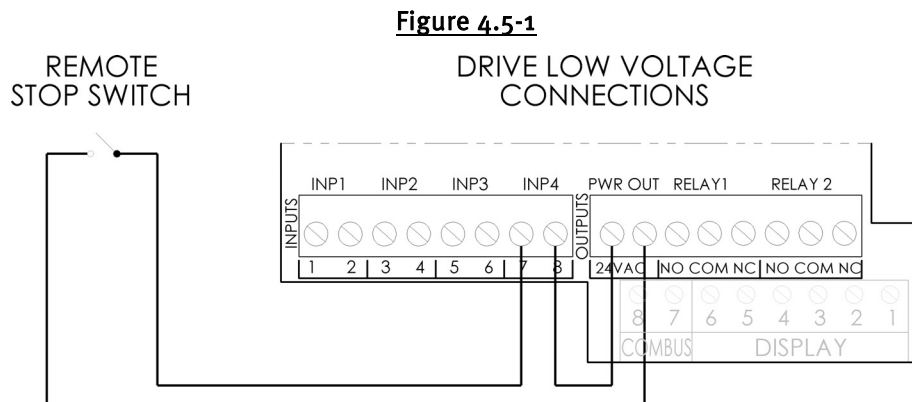

Note: Connection wire must be rated for a minimum of 350V. Switch must be latching type; pump is stopped when circuit is closed.

USE ONLY HAYWARD GENUINE REPLACEMENT PARTS

5. Startup & Operation

5.1. Prior to Start-Up

If it is necessary to perform a water pressure test prior to initial use to ensure plumbing system is functioning properly, then the following criteria should be maintained for this test:

1. Have a professional perform this test.
2. Ensure all Hayward pump and system components are removed from system prior to performing test.

 **WARNING** – If circulation equipment must remain in the plumbing system during water pressure test, do not apply more than 10 psi pressure to the system. Be sure water pressure has been released, using the filter manual air relief valve, before removing pump strainer cover.

 **WARNING** – All suction and discharge valves **MUST** be OPEN, as well as filter air relief valve (if available) on filter, when starting the circulating pump system. Failure to do so could result in severe personal injury.

5.2. Starting/Priming the Pump

Fill strainer housing with water to suction pipe level. If water leakage occurs from anywhere on the pump or filter, DO NOT start the pump. If no leakage occurs, stand at least 10 feet from pump and/or filter and proceed with starting the pump.

 **WARNING** – Return to filter to close filter manual air relief valve when a steady stream of water (not air or air and water) is discharged from valve. Failure to do so could result in severe personal injury.

 **ATTENTION** – **NEVER OPERATE THE PUMP WITHOUT WATER.** Water acts as a coolant and lubricant for the mechanical shaft seal. NEVER run pump dry. Running pump dry may damage seals, causing leakage, flooding, and voids warranty. Fill strainer housing with water before starting motor.

 **ATTENTION** – Do NOT add chemicals to pool/spa system directly in front of pump suction. Adding undiluted chemicals may damage pump and voids warranty.

 **ATTENTION** – Before removing strainer cover:

1. STOP PUMP before proceeding.
2. CLOSE VALVES in suction and outlet pipes.
3. RELEASE ALL PRESSURE from pump and piping system using filter manual air relief valve. See filter owner's manual for more details.
4. If water source is higher than the pump, pump will prime itself when suction and outlet valves are opened. If water source is lower than the pump, unscrew and remove strainer cover; fill strainer housing with water.
5. Clean and lubricate strainer cover O-ring with "Jack's 327" if necessary.
6. Replace strainer cover on strainer housing; turn clockwise to tighten cover.

NOTE - Tighten strainer cover lock ring by hand only (no wrenches).

Turn on power and wait for pump to prime, which can take up to fifteen (15) minutes. Priming time will depend on vertical length of suction lift and horizontal length of suction pipe. If pump does NOT prime within 15 minutes, stop motor and determine cause. Be sure all suction and discharge valves are open when pump is running. See Troubleshooting Guide.

5.3. User Interface Summary

Figure 5.3-1

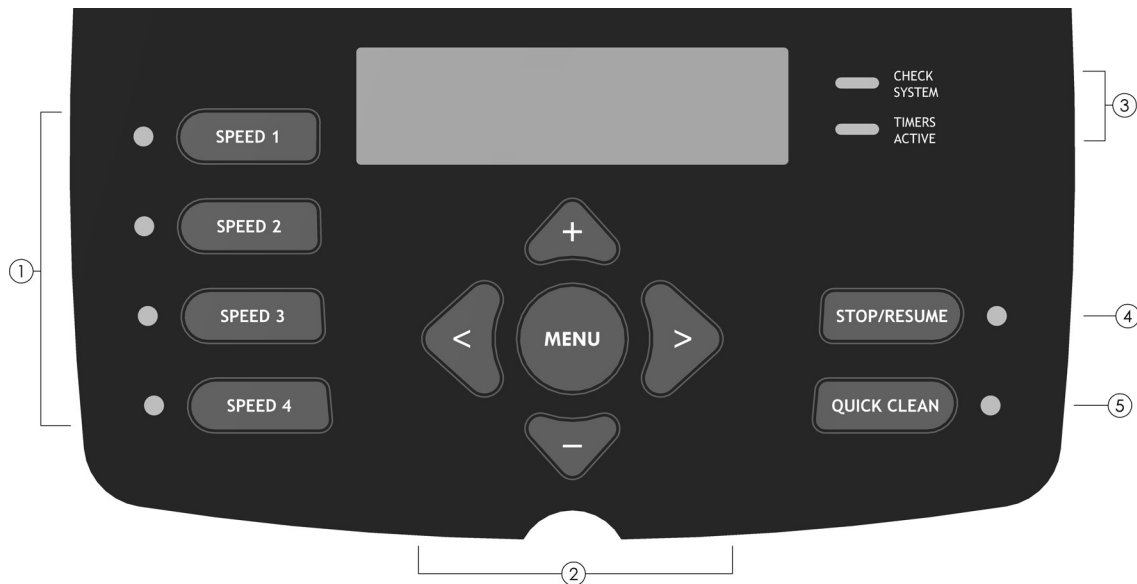

1. **Preset Speeds:** Buttons labeled SPEED 1 thru SPEED 4 can be used to run the pump at a predetermined speed for a certain length of time. Preset Speed settings can be quickly updated using the + and - arrow buttons and then holding the desired speed button down for at least 3 seconds. When a speed is selected, the LED beside the button will illuminate to indicate operation.
 - a. **Default Speeds:**
 - Speed 1: 1000 rpm
 - Speed 2: 1750 rpm
 - Speed 3: 2500 rpm
 - Speed 4: 3250 rpm
2. **Menu/navigation buttons:** The MENU button will scroll through the setup menus when pressed. The < and > arrow buttons are used to move between displays and to select parameters to edit, and the + and - arrow buttons are used to change parameters.
3. **Status LEDs:** The CHECK SYSTEM LED will illuminate when the pump is experiencing an error condition. For SP3400VSPVR, it will also flash on and off when the system is in QUICK CLEAN mode to indicate that the SVRS feature is inactive (see “Quick Clean” below). The TIMERS ACTIVE LED will illuminate once timers have been programmed to run the pump, even if the pump is not presently running.
4. **Stop/Resume:** This button is used to stop the pump to allow strainer basket cleaning, etc. When this button is pressed, the pump will remain stopped until the button is pressed a second time to resume normal operation. When the pump is stopped, the red LED beside the button will illuminate to indicate that the pump has been stopped.
5. **Quick Clean:** QUICK CLEAN is a mode intended for use when the pool will be cleaned with a suction side vacuum. While in Quick Clean mode for SP3400VSPVR, the SVRS feature is disabled for 60 minutes to prevent nuisance tripping during cleaning. Users will be prompted to and verify that all bathers are out of the pool during this time. The LED beside the button will illuminate when Quick Clean is active, and the CHECK SYSTEM LED will blink indicating that the SVRS feature is disabled.

5.4. Menu Outline

1. **Configuration Menu** (see section 5.6)
 - a. Set Day and Time
 - b. Speed Selection

USE ONLY HAYWARD GENUINE REPLACEMENT PARTS

- c. MAX Allowed Speed
 - d. MIN Allowed Speed
 - e. Set max-speed Prime Period
 - f. Remote Control Mode
 - g. Set COMM Bus Address
2. **Timer Menu** (see section 5.7)
 - a. Rename Timer X (X = 1-8)
 - b. Pump Speed for Timer X (X = 1-8)
 - c. Start/Stop Time for Timer X (X = 1-8)
 - d. Choose Days for Timer X (X = 1-8)
 3. **Speeds Menu** (see section 5.8)
 - a. Speed X Name (X = 1-4)
 - b. Speed X Duration (X = 1-4)
 - c. Speed X Speed (X = 1-4)
 4. **Diagnostics Menu** (see section 5.9)
 - a. Drive Serial Number
 - b. Motor Drive/Display Firmware Revisions
 - c. Input Voltage Status
 - d. Motor Current
 - e. Power Usage
 - f. Driver/Heatsink Temperatures
 - g. COMM Bus Status
 - h. Event Log (if applicable)

5.5. Initial startup

After plumbing and wiring are complete, the variable speed drive must be configured prior to use. When power is applied to the drive for the first time, the following informational screens are displayed.

	<u>Screen</u>	<u>Comments</u>
1.	Hayward EcoStar Pump SP3400VSP	Pump SKU will be shown at the bottom of the screen.
2.	Thursday 1:27p 0rpm 26 Watts	
3.	Pump is stopped Factory default op.	

Note: Speeds can be selected at this time to temporarily run the pump, however, it is recommended that the drive configuration and timers be set according to individual installation site requirements (see section 10 for more details). After the configuration/timer settings are changed, “Factory default Op.” is replaced by “No timers are set”. At this point, pressing the MENU button will select the Configuration Menu.

5.6. Configuration Menu

	<u>Screen</u>	<u>Buttons Used</u>	<u>Comments</u>
1.	Configuration Menu Locked	↔	Press & hold < and > buttons for several seconds to unlock Configuration Menu
2.	Configuration Menu press > to enter	↔	Use > to enter Configuration Menu
3.	Use + / - to adjust, > go to next item		
4.	Time: Th 1:27PM + change or > skip	+- ↔	Use + to change clock setting Use > if clock is correct
5.	Set Day and Time Thursday 1:27p	+- ↔	Adjust day/time setting Move to next selection, then to next menu item
6.	Speed Selection rpm	+- ↔	Select whether to display speed in rpm (Revolutions per Minute) or % of full speed Move to next menu item
7.	MAX allowed speed 3450 (600-3450rpm)	+- ↔	Set maximum running speed of pump Move to next menu item
8.	MIN allowed speed 600 (600-3450rpm)	+- ↔	Set minimum running speed of pump Move to next menu item

Note: For SP3400VSPVR. Minimum allowed speed cannot be set lower than 1000 rpm.

9.	Set max-speed Prime Period: Auto Sense	+- ↔	Select pump prime mode Move to next menu item
----	---	---------	--

Note: User may set the pump to automatically sense when it has reached full prime. User may also set the pump to prime at the maximum allowed speed for 3 minutes. The 3-minute prime mode should be used if the maximum allowed speed is set below 3000 rpm.

10.	Remote Control Mode Standalone/Hayward	+- ↔	Select Standalone/Hayward or Relay Control Move to next menu item
-----	---	---------	--

(Details in section 3.10)

11.	Set COMM Bus Address Pool Filter (1)	+- ↔	Select COMM Bus Address for pump Move to next menu item
-----	---	---------	--

Note: The pump can be controlled by a Hayward control through the COMM Bus, or by a third party control using relay contacts to select speeds set in the Timer Menu. If the COMM Bus is selected, then a bus address must be

chosen for the pump. If the Relay Control is selected, the timer speed settings are invoked when inputs 1-3 (INP1-INP3) are selected according to the following table:

Timer Speed	INP1 Status	INP2 Status	INP3 Status
1	OFF	OFF	OFF
2	ON	OFF	OFF
3	OFF	ON	OFF
4	ON	ON	OFF
5	OFF	OFF	ON
6	OFF	ON	ON
7	ON	OFF	ON
8	ON	ON	ON

- | | | | |
|-----|---|----------|---|
| 12. | Reset all parameters
+ for yes; > to skip | +-
<> | Use + to reset to factory default settings
Use > to skip reset |
| 13. | Are you sure?
+ for yes; - for no | +-
<> | Confirm reset of all parameters
Move to next menu item |
| 14. | Use Timers Menu to
set timeclocks. | | |

5.7. Timer Menu

	<u>Screen</u>	<u>Buttons Used</u>	<u>Comments</u>
1.	Timer Menu Press > to enter	<>	Use > to enter Timer Menu
2.	Timer 1 1725rpm --- Off ---		
3.	Press + to change; Press > next timer	+- <>	Use + to change displayed timer Use > to skip to next timer
4.	T1: Timer 1 +/- rename; speed >	+- <>	Use + to rename timer Use > to set motor speed for timer
5.	Timer 1 1725rpm +/- adjust; times >	+- <>	Use to set speed for timer Use > to set start/stop time
6.	Timer 1 1725rpm --- Off ---	+- <>	Use to set start/stop time for timer Use > to choose days of operation for timer

USE ONLY HAYWARD GENUINE REPLACEMENT PARTS

- | | | | |
|----|--|----------|--|
| 7. | Choose Days
7D 7 days a week > | +-
<> | Use to chose days of operation for timer
Move to next menu item |
|----|--|----------|--|

Note: When start/stop times are set to be the same, the timer is deactivated. Each timer can be set to run on specific days of the week. Options are to run 7 days per week, 5 days per week (Monday thru Friday), or on a single day (Monday thru Sunday). Each timer is set up in this same manner. When the pump is powered and the timers are set up, the Timers Active LED will illuminate. If the timers are set up such that their run times overlap, the timers will run in priority from Timer 1 to Timer 8. In other words, if Timer 1 is set to run from 8:00 am to 12:00 pm, and Timer 2 is set to run from 10:00 am to 2:00 pm, the pump will run Timer 1 from 8:00 am to 12:00 pm, and will then switch to run Timer 2 until 2:00 pm. Default setting for Timer 1 is to start at 12:00 am, and end at 11:45 pm.

5.8. Preset Speed Setup Menu

	<u>Screen</u>	<u>Buttons Used</u>	<u>Comments</u>
1.	Speeds Menu Press > to enter	<>	Use > to enter Speeds Menu
2.	Speed 1 Name Speed 1	+- <>	Use to rename displayed speed Move to next menu item
3.	Speed 1 Duration 0:30 hours	+- <>	Use to set duration of speed Move to next menu item
4.	Speed 1 Speed 1725 (600-3450rpm)	+- <>	Use to set motor speed for displayed speed Move to next menu item

Note: Each time a preset speed is selected, it will run for the programmed duration. Multiple presses of the speed button will add more time according to the set duration up to a maximum of 12 hours.

Note: Preset Speed settings can be quickly updated using the + and - arrow buttons and then holding the desired speed button down for at least 3 seconds.

5.9. Diagnostic Menu

	<u>Screen</u>	<u>Buttons Used</u>	<u>Comments</u>
1.	Diagnostic Menu Press > to enter	<>	Use > to enter Diagnostic Menu and toggle between displays
2.	Serial Number 03100002		Displays motor drive serial number.
3.	Drive Rev: 2.02 Display Rev: 1.16		Displays drive board and display board firmware revisions.
4.	Product Version SP3400VSP		Displays pump SKU. For SP3400VSPVR, displays current status of SVRS protection.

USE ONLY HAYWARD GENUINE REPLACEMENT PARTS

5.	Input Voltage Within Range		Real-time display of line voltage status connected to drive (within range, too high, or too low).
6.	Motor Current 1.1A (0-13.0A)		Real-time display of motor input current.
7.	Power Usage 225W (0-2650W)		Real-time display of pump power usage.
8.	Driver: 78C Heatsink: 67C		Display showing temperature of motor drive chip and heatsink.
9.	Comm Bus Online (Addr: 1)		Display showing COMM Bus communication status between the motor drive and Hayward control.
10.	Event log Press + to view	+-	Use + to view event log

Note: For troubleshooting purposes, the Event Log will record the last eight error and/or trip conditions, as well as the amount of time that has elapsed since the condition occurred.

5.10. Stop/Resume

Screen

1.

**Pump is stopped;
press STOP/RESUME**
2.

**again to resume
normal operation.**

Note: When Stop/Resume is pressed at any time during normal operation, the above message will be displayed. The pump will stop within several seconds, and will remain stopped until Stop/Resume is pressed a second time, at which point the pump will resume normal operation.

5.11. Quick Clean

Screen

1.

**SVRS inactive in
Quick Clean mode.**
2.

**No bathers in water
During Quick Clean**

3. **Bathers in water?**
+ = yes; - = no

Note: For SP3400VSPVR only, the SVRS feature is disabled during Quick Clean mode. When Quick Clean is pressed, the above message is displayed to alert the user that SVRS is disabled, and that all bathers should exit the pool during Quick Clean. If bathers are in the water, pressing + will return the pump to normal operation. If bathers are not in the water, pressing – will allow the pump to run in Quick Clean mode, where it will run at the Max Allowed Speed set in the Configuration Menu for 60 minutes. When Quick Clean is selected for SP3400VSP, the pump will immediately proceed to Quick Clean mode.

4. **SVRS Inactive**
Quick Clean running

5. **SVRS Inactive**
3200 rpm for 60 min;

6. **SVRS Inactive**
Press resume to end.

Note: The above message will be displayed while Quick Clean is running. For SP3400VSPVR, the check system light will also flash on and off every two seconds as an additional reminder that SVRS is inactive. Quick Clean mode expires after 60 min, and it may be cancelled early by pressing the Stop/Resume button, at which time the pump would return to normal operation. For SP3400VSP, the SVRS Inactive message will not be shown, and the Check System LED will not flash.

5.12. Remote Stop

Screen

1. **Remote Stop**
is engaged

Note: The above message will be displayed when an installed remote stop switch is activated. The pump will remain stopped until the remote stop switch is deactivated.

6. Maintenance

- Clean strainer basket regularly. Do NOT strike basket to clean. Inspect strainer cover gasket regularly and replace as necessary.
- Hayward pumps have self-lubricating motor bearings and shaft seals. No lubrication is necessary.
- Keep motor clean. Insure motor air vents are free from obstruction to avoid damage. Do NOT use water to hose off motor.
- Occasionally, shaft seals must be replaced, due to wear or damage. Replace with genuine Hayward seal assembly kit. See “Shaft Seal Change Instructions” in this manual.

7. Storage / Winterization



WARNING – Separation Hazard. Do not purge the system with compressed air. Purging the system with compressed air can cause components to explode, with risk of severe injury or death to anyone nearby. Use only a low pressure (below 5 PSI), high volume blower when air purging the pump, filter, or piping.

USE ONLY HAYWARD GENUINE REPLACEMENT PARTS



⚠ ATTENTION – Allowing the pump to freeze with water in it will void the warranty.

⚠ ATTENTION – Use ONLY propylene glycol as antifreeze in your pool/spa system. Propylene glycol is non-toxic and will not damage plastic system components; other anti-freezes are highly toxic and may damage plastic components in the system.

Drain all water from pump and piping when expecting freezing temperatures or when storing pump for a long time (see instructions below). Gravity drain system as far as possible.

Keep motor dry and covered during storage. To avoid condensation/corrosion problems, do NOT cover or wrap pump with plastic film or bags.

7.1. Storing Pump For Winterization



⚠ WARNING – To avoid dangerous or fatal electrical shock hazard, turn OFF power to motor before draining pump. Failure to disconnect power may result in serious personal injury or death.

1. Drain water level below all inlets to the pool.
2. Remove drain plugs and strainer cover from strainer housing. (See “Parts Diagram” in section 9.1 of this manual for pump component locations.)
3. Disconnect pump from mounting pad, wiring (after power has been turned OFF), and piping.
4. Once the pump is fully drained of water, re-install the strainer cover and drain plugs. Store pump in a dry area.

8. Shaft Seal Change Instructions

IMPORTANT SAFETY INSTRUCTIONS PLEASE READ AND FOLLOW ALL INSTRUCTIONS

When servicing electrical equipment, basic safety precautions should always be observed including the following. Failure to follow instructions may result in injury.

- **⚠ WARNING** – To reduce risk of injury, do not permit children to use this product.
- Disconnect all electrical power service to pump before beginning shaft seal replacement.
- Only qualified personnel should attempt rotary seal replacement. Contact your local authorized Hayward Dealer or service center if you have any questions.
- See “Parts Diagram” Figure 9.1-1 for pump component locations.

Exercise extreme care in handling both the rotating and the stationary sections of the two-part replacement seal. Foreign matter or improper handling will easily scratch the graphite and ceramic sealing surfaces.

* Refer to Figure 8.6-1 for motor drive removal.

8.1. Removing the Motor Assembly

1. Remove the six (6) 5/16" x 2" hex head bolts (item #17), which hold the motor assembly to the pump/strainer housing (item #3), using a 1/2" wrench or socket.
2. Slide the motor assembly out of the pump/strainer housing (item #3), exposing the diffuser (item #9). Remove the two diffuser screws (item #7), and pull the diffuser (item #9) off of the seal plate (item #15) to expose the impeller (item #12).

8.2. Removing the Impeller

3. Remove the motor fan shroud (item #24) by removing the four (4) screws and pulling the shroud away from the motor.
4. To prevent the motor shaft from turning, secure using a 5/16" hex wrench in the socket on the motor shaft.

USE ONLY HAYWARD GENUINE REPLACEMENT PARTS

5. Rotate the impeller screw (item #10) clockwise (note that screw has left-hand thread) and remove. Remove the impeller (item #12) by rotating counterclockwise.

8.3. Removing the Ceramic Seat

6. Remove the spring seal assembly (item #13) and seal plate (item #15) from the motor by removing the four (4) 3/8" x 1" bolts (item #18) that secure it to the motor, using a 9/16" wrench or socket. Remove the motor support bracket (item #20) from the seal plate (item #15).
7. Press the ceramic seat with rubber cup out of the seal plate (item #15). If tight, use a small screwdriver to tap seal out.

STOP - Clean all recesses & parts to be reassembled. Inspect gaskets & replace if necessary.

8.4. Seal Installation

8. Clean and lightly lubricate the motor shaft and seal recesses in the seal plate (item #15) with a dilute solution of non-granulated liquid-type soap. Gently wipe the polished face of the ceramic seal with a soft cotton cloth. Lubricate the rubber cup on the ceramic seat and press it firmly into the recess of the seal plate (item #15), with the polished ceramic surface facing out.
9. Reassemble the motor to the seal plate (item #15) using the four (4) 3/8" x 1" bolts (item #18), and re-attach the motor support (item #20) to the seal plate (item #15).
10. Gently wipe the black, polished surface of the spring seal assembly (item #13) with a soft cotton cloth.
11. Press the spring seal assembly (item #13) onto the motor shaft, with the black polished surface facing the ceramic seat.

8.5. Replacing the Impeller and Diffuser

12. Screw the impeller (item #12) onto the motor shaft in a clockwise direction, and screw the impeller screw (item #10) into the motor shaft in a counterclockwise direction. Tighten snugly by holding motor shaft with wrench as noted in step #4. Place the impeller ring (item #11) back onto the impeller (item #12), with flange facing towards the diffuser (item #9).
13. Place the diffuser (item #9) over the impeller (item #12) and onto the seal plate (item #15), aligning the three pins on the diffuser (item #9) with the three holes on the seal plate (item #15). Replace the two diffuser screws (item #7).

8.6. Replacing the Motor Assembly

14. Re-attach motor fan shroud (item #24) using the four (4) hex headed screws. Slide the motor assembly, with the diffuser (item #9) in place, into pump/strainer housing (item #3), being careful not to disturb the diffuser gasket (item #8).
15. Fasten assembly to pump/strainer housing (item #3) using the six (6) 5/16" x 2" bolts (item #17). (Be sure housing gasket (item #14) is in place, and lubricated. Replace if damaged). Tighten bolts alternately and evenly to 185 inch-pounds according to housing bolt torque pattern detail.

* Refer to Figure 8.6-1 for motor drive mounting.

Figure 8.6-1: Removing the Variable Speed Drive

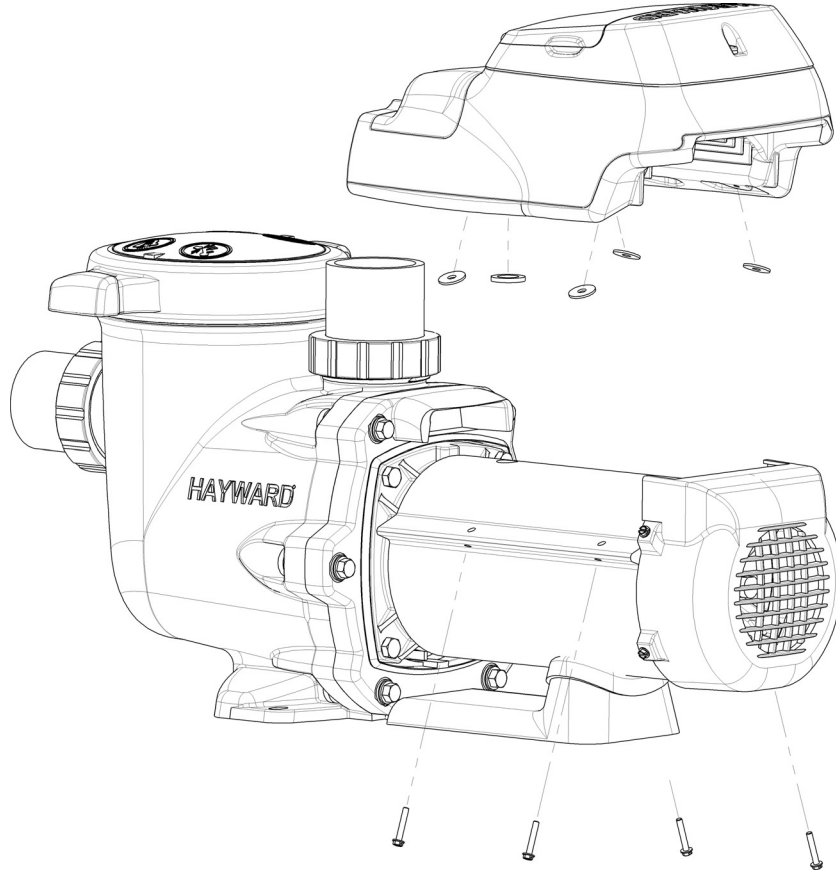

Note: Motor leads must be disconnected prior to removing drive, and reconnected when new drive is mounted. Take care to ensure that the motor leads are not pinched between the drive enclosure and the motor during assembly. The drive mounting screws must be tightened to 30 inch-pounds.

9. Replacement Parts

9.1. Parts Diagram

Figure 9.1-1

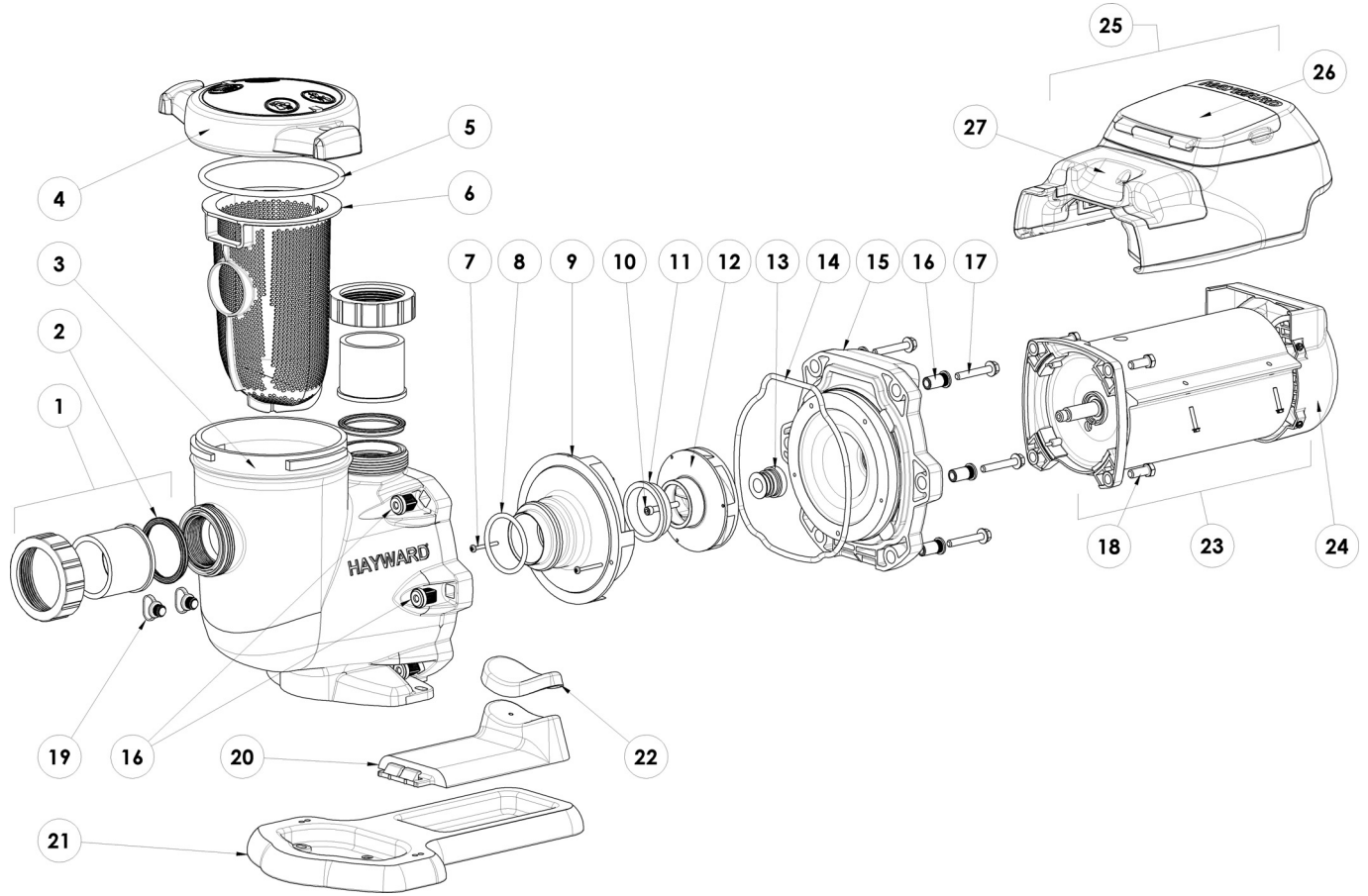

9.2. Parts Listing

Ref. No.	Part No.	Description	Ctn. Qty.
1	SPX3200UNKIT	Union Connector Kit (Includes Union Nut, Union Connector, Union Gasket - 2 ea.)	1
2	SPX3200UG	Union Gasket	1
3	SPX3200A	Pump Strainer Housing, 2" x 2 1/2" with Drain Plugs, threaded style	1
4	SPX3200DLS	Strainer Cover Kit (Includes Strainer Cover, Lock Ring, O-Ring)	10
	SPX3200DLSB	Strainer Cover Kit (Biguanide Sanitizer Applications Only; NOT Pressure Testable)	10
5	SPX3200S	Strainer Cover O-Ring	10
6	SPX3200M	Strainer Basket	15
7	SPX3200Z8	Diffuser Screw	1
8	SPX4000Z1	Diffuser O-Ring	10
9	SPX3200B3	Diffuser	1
10	SPX3200Z1	Impeller Screw	1

USE ONLY HAYWARD GENUINE REPLACEMENT PARTS

Ref. No.	Part No.	Description	Ctn. Qty.
11	SPX3021R	Impeller Ring	1
12	SPX3220C	Impeller for 2 HP with Impeller Screw (Full Rate)	10
13	SPX3200SA	Shaft Seal Assembly	10
14	SPX3200T	Housing O-Ring	10
15	SPX3200E	Seal Plate	1
16	SPX3200Z211	Housing Insert/Seal Plate Spacer Kit	1
17	SPX3200Z3	Housing Bolt	10
18	SPX3200Z5	Motor Bolt	1
19	SPX4000FG	Drain Plug with O-Ring	10
20	SPX3200GA	Bracket, Motor Support	1
21*	SPX3200WF	Riser Base	1
22	SPX3200Q	Adapter-Motor Support	100
23	SPX3400Z1ECM	Motor Assembly	1
24	SPX3400FAN	Motor Fan Shroud	5
25	SPX3400DR	Motor Drive	1
	SPX3400DRVR	Motor Drive, SVRS	1
26	SPX3400DR4	Motor Drive Display Cover	5
27	SPX3400DR2	Motor Drive Wiring Cover	5
	SPX3400LCD	Digital Control Interface Assembly	1
	SPX3400DRKIT	Wall Mount Kit	5

* WHISPERFLO is a registered trademark of Pentair Water Pool & Spa, Inc., which is used herein for identification purposes only. This is a retrofit base for existing WHISPERFLO pump installations. Pentair Water Pool & Spa, Inc. is not affiliated with Hayward Pool Products.

10. Energy Efficiency Overview

The energy consumed by a pool pump is measured in terms of Watts (W) or kilowatts (kW). The EcoStar Variable Speed Pump displays power consumption in Watts. Given this information, it is very easy to determine the cost of operating the pump:

Power consumption of pump X Cost of electricity = Cost of Pump Operation per Hour

Example: EcoStar Variable Speed Pump operating at 300 W. Cost of electricity = \$0.10 per kWh

300 W = 0.3 kW

0.3 kW X \$0.10/kWh = \$0.30 per hour

Note the power consumption is greatly affected by the speed of the pump. Lowering the speed of the pump can drastically reduce the power that is consumed. Below are some of the major benefits of running the pump at lower speeds.

Benefits of running at low speeds

- Save electricity and money
- Better filtration – the filter can often remove smaller particles when the water moves slower
- Quiet operation
- Reduced Total Dynamic Head – less stress on equipment (e.g. filter) which can lengthen equipment life

USE ONLY HAYWARD GENUINE REPLACEMENT PARTS



When determining the speed(s) to operate your pump, you must also take into account the minimum requirements for proper sanitation and equipment/water feature functionality.

It is recommended you filter (“turnover”) all the water in the pool at least once every 24 hours. Check with local requirements for the minimum turnover rate. Running the pump at a lower speed may require running the pump for a longer period of time in order to meet the turnover requirements for proper sanitation.

Equipment such as heaters, skimmers, and chlorinators require minimum flows to operate correctly. Refer to individual equipment manuals for specific requirements for low flow operation.

After setting the pump speed(s), it is recommended you check all other equipment/water features are functioning as intended. For example, when running at a low speed for daily filtration, verify water is adequately flowing over the skimmer weirs. Operate the pump at higher speeds for the shorter periods of time needed to operate a heater, water feature, etc.

11. Troubleshooting

11.1. General Problems

- **Motor Will NOT Start:**
 1. Make sure the terminal board connections agree with the wiring diagram on the pump data plate label.
 2. Be sure the pump is wired for the available field supply voltage (230VAC).
 3. Check for and correct any improper or loose wiring connections; open switches or relays; tripped circuit breakers, or blown fuses.
 4. Manually check the rotation of the motor shaft for free movement and lack of obstruction. Correct if necessary.
- **Motor Shuts OFF:**
 1. Check for low voltage or power drop at the motor (frequently caused by undersized wiring). Contact a qualified professional to verify the electrical connections.
- **Motor Hums, But Does NOT Start:**
 1. Impeller jammed with debris. Have a qualified repair professional open the pump and remove the debris.
- **Pump Won't Prime:**
 1. Empty pump/strainer housing. Make sure the pump/strainer housing is filled with water and the cover o-ring is clean. Ensure the o-ring is properly seated in the cover o-ring groove. Ensure the o-ring sealing surface is lubricated with “Jack’s 327” and that the strainer cover is locked firmly in position. Lubricant will help to create a tighter seal.
 2. Loose connections on the suction side. Tighten the pipe/union connections.
NOTE - Any self-priming pump will not prime if there are suction air leaks. Leaks will result in bubbles emanating from the return fittings on the pool wall.
 3. Leaking O-ring or packing glands on valves. Tighten, repair, or replace the valves.
 4. Strainer basket or skimmer basket loaded with debris. Remove the strainer housing cover or the skimmer cover. Clean the basket, and refill the strainer housing with water. Tighten the cover.

USE ONLY HAYWARD GENUINE REPLACEMENT PARTS

5. Suction side clogged. Contact a qualified repair professional. You should have 5” - 6” of vacuum at the strainer cover (your pool dealer can confirm this with a vacuum gauge). You may be able to check by removing the skimmer basket and holding an object over the bottom port with the skimmer full and the pump running. If no suction is felt, check for line blockage.
 - a. If the pump develops a vacuum, check for a blocked suction line or a dirty strainer basket. An air leak in the suction piping may be the cause.
 - b. If the pump does not develop a vacuum and the pump has sufficient “priming water”:
 - i. Re-check the strainer housing cover and all threaded connections for suction leaks. Check if all system hose clamps are tight.
 - ii. Check voltage to ensure that the motor is rotating at full rpm’s.
 - iii. Open the housing cover and check for clogging or obstruction in suction. Check the impeller for debris.
 - iv. Remove and replace the shaft seal only if it is leaking.
- **Low Flow – Generally:**
 1. Clogged or restricted strainer or suction line. Contact a qualified repair professional.
 2. Undersized pool piping. Correct the piping size.
 3. Plugged or restricted discharge line of filter, valve partially closed (high gauge reading). Sand filters – backwash as per manufacturer’s instructions; D.E. filters – backwash as per manufacturer’s instructions; Cartridge filters – clean or replace the cartridge.
 4. Air leak in suction (bubbles issuing from return fittings). Re-tighten the suction and discharge connections using Teflon tape. Inspect other plumbing connections, and tighten as required.
 5. Plugged, restricted, or damaged impeller. Replace the impeller including a new seal assembly.
 - **Noisy Pump:**
 1. Air leak in suction piping, cavitations caused by restricted or undersized suction line or leak at any joint, low water level in pool, and unrestricted discharge return lines. Correct the suction condition or throttle return lines, if practical. Holding your hand over the return fitting will sometimes prove this, or by putting in a smaller eyeball fitting.
 2. Vibration due to improper mounting, etc. Mount the pump on a level surface and secure the pump to the equipment pad.
 3. Foreign matter in the pump housing. Loose stones/debris hitting the impeller could be the cause. Clean the pump housing.
 4. Motor bearings noisy from normal wear, rust, overheating, or concentration of chemicals causing seal damage, which will allow chlorinated water to seep into bearings wiping out the grease causing bearing to whine. All seal leaks should be replaced at once.
 - **Interference With Home Automation/Power Line Communication Equipment:**
 1. Make sure the terminal board connections agree with the wiring diagram on the pump data plate label.
 2. Check for and correct any improper or loose wiring connections.
 3. Install noise filter (from home automation/power line communication equipment vendor) to prevent equipment interference.

11.2. Error Codes

Code:	Indications:
Drive Error! Drive is overheated	Indicates that the internal components of the drive have become overheated. Motor airflow path should be checked for obstructions and cleared if present.
Drive Error! PFC Circuit Hi	Indicates that the internal drive voltage is too high. Verify that line voltage is within 10% of pump rated voltage.
Drive Error! Drive Overload	Indicates that the motor is drawing excessive current. Check impeller, diffuser, and shaft seal for issues.
Drive Error! PFC Circuit Low	Indicates that the internal drive voltage is too low. Verify that line voltage is within 10% of pump rated voltage.

USE ONLY HAYWARD GENUINE REPLACEMENT PARTS

Code:	Indications:
Drive Error! AC voltage too low	Indicates that the line voltage has dropped below 185 VAC and pump stops. Verify that line voltage is within 10% of pump rated voltage.
Drive Error! AC voltage too high	Indicates that the line voltage has risen above 264 VAC and pump stops. Verify that line voltage is within 10% of pump rated voltage.
Drive Error! Heatsink overheated	Indicates that the heatsink of the drive have become overheated. Motor airflow path should be checked for obstructions and cleared if present. Drive will continue to monitor this temperature and pump will restart automatically when this temperature reaches an acceptable limit.
Drive Error! Drive failed to start	Indicates that the drive was not able to start the motor. Motor connections to drive should be verified. Drive will attempt to restart the motor 3 times before pump stall error is displayed.
Drive Error! Pump has stalled	Indicates that the drive was not able to start the motor after 3 attempts. Motor connections to drive should be verified.
Drive Error! Memory failure	Indicates that the drive memory has been damaged or corrupted and drive may need to be replaced.
Drive Error! Prime failed	Indicates that the pump was not able to prime within 15 minutes of startup. Plumbing and fittings should be checked for potential air leaks and corrected.

12. Warranty

HAYWARD® LIMITED WARRANTY

To Buyer, as original purchaser of this equipment, Hayward Pool Products, 620 Division Street, Elizabeth, New Jersey, warrants its products free from defects in materials and workmanship for a period of **ONE (1)** year from the date of purchase.

Parts which fail or become defective during the warranty period, except as a result of freezing, negligence, improper installation, use, or care, shall be repaired or replaced, at our option, without charge, within 90 days of the receipt of defective product, barring unforeseen delays.

To obtain warranty replacements or repair, defective components or parts should be returned, transportation paid, to the place of purchase, or to the nearest authorized Hayward service center. For further Hayward dealer or service center information, contact Hayward customer service department. No returns may be made directly to the factory without the express written authorization of Hayward Pool Products.

To original purchasers of this equipment, Hayward Pool Products warrants its products to be free from defects in materials and workmanship for a period of **ONE (1)** year from the date of purchase.

Filters which become defective during the warranty period, except as a result of freezing, negligence, improper installation, use or care, shall be repaired or replaced, at our option, without charge.

All other conditions and terms of the standard warranty apply.

Hayward shall not be responsible for cartage, removal and/or reinstallation labor or any other such costs incurred in obtaining warranty replacements.

The Hayward Pool Products warranty does not apply to components manufactured by others. For such products, the warranty established by the respective manufacturer will apply.

Some states do not allow a limitation on how long an implied warranty lasts, or the exclusion or limitation of incidental or consequential damages, so the above limitation or exclusion may not apply to you.

This warranty gives you specific legal rights, and you may also have other rights, which vary from state to state.

* Supersedes all previous publications.

Hayward Pool Products
620 Division Street
Elizabeth, NJ 07207

USE ONLY HAYWARD GENUINE REPLACEMENT PARTS

13. Product Registration

DATE OF INSTALLATION	_____
INITIAL PRESSURE GAUGE READING (CLEAN FILTER)	_____
PUMP MODEL	_____

*Retain this Warranty Certificate in a safe and convenient location for your records



DETACH HERE: Fill out bottom portion completely and mail within 10 days of purchase/installation or register online.

EcoStar

Warranty Card Registration

Register online at www.haywardnet.com

Please Print Clearly:

First Name _____ Last Name _____

Street Address _____

City _____ State _____ Zip _____

Phone Number _____ Purchase Date _____

E-Mail Address _____

Serial Number																				
---------------	--	--	--	--	--	--	--	--	--	--	--	--	--	--	--	--	--	--	--	--

(10-17 digit number)

Model Number _____

Pool Capacity _____ (U.S. Gallons)

Please include me on all e-mail communications regarding Hayward Equipment or promotions.

Mail to: Hayward Pool Products, 620 Division Street, Elizabeth, NJ 07207

Attn: Warranty Dept

Or REGISTER YOUR WARRANTY ON-LINE AT WWW.HAYWARDNET.COM

Years Pool has been in service
 < 1 year 1-3 4-5 6-10 11-15 >15

Purchased from _____

Builder Retailer Pool Service Internet/Catalog

Company Name _____

Address _____

City _____ State _____ Zip _____

Phone _____

Type of Pool:
 Concrete/Gunite Vinyl Fiberglass
 Other _____

New Installation Replacement

Installation for:
 In Ground Spa

is a registered trademark and EcoStar is a trademark of Hayward Industries, Inc.

©2010 Hayward Industries. All rights reserved.