

Little GIANT[®]

Pump Company

1-A SERIES



Features

- Epoxy coated die-cast aluminum housing
- Oil-filled motor housing
- 7' maximum lift
- 70 watts
- 1/4" MNPT discharge
- Impedance protected
- For submersible use only

Construction

- Intermittent Liquid Temp. up to — 120°F
- Intake — N/A
- Discharge — 1/4" MNPT
- Housing — Epoxy coated cast aluminum
- Cover — Epoxy coated cast aluminum
- Volute — Polypropylene
- Impeller — Polypropylene
- Shaft Seal — Nitrile
- Screen — Polypropylene

Small submersible oil-filled pump with epoxy coated cast aluminum housing. For commercial, industrial and home applications including statuary fountains, water displays, air conditioners, machine tool coolants, and many other applications where liquid must be transferred or recirculated. This compact 170 GPH pump features a 1/4" MNPT discharge, 7' shut-off head capability, and screened inlet.

Little Giant Pump Co.

1-A SERIES

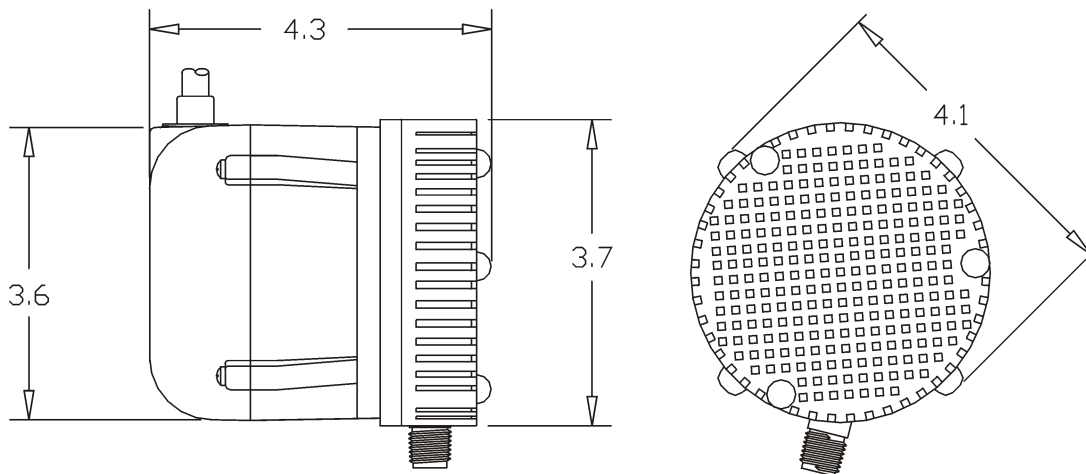

Specifications

Model No.	Item No.	Discharge Size	Listing(s)	HP	Volts	Hertz	Amps	Watts	Performance (GPH @ Head)			Shut Off		Pwr. Cord (ft)	Weight (Lbs.)
									1'	3'	5'	Feet	PSI		
1-AA	500000	1/4" MNPT	UR	1/200	115	60	1.1	70	170	140	100	7	3.0	3	3.17
1-AA-18	500500	1/4" MNPT	UL/CSA	1/200	115	60	1.1	70	170	140	100	7	3.0	18	4.17
1-A	500203	1/4" MNPT	UL	1/200	115	60	1.1	70	170	140	100	7	3.0	6	3.33
1-AT	500286	1/4" MNPT	UL/CSA	1/200	115	60	1.1	70	170	140	100	7	3.0	10	3.50

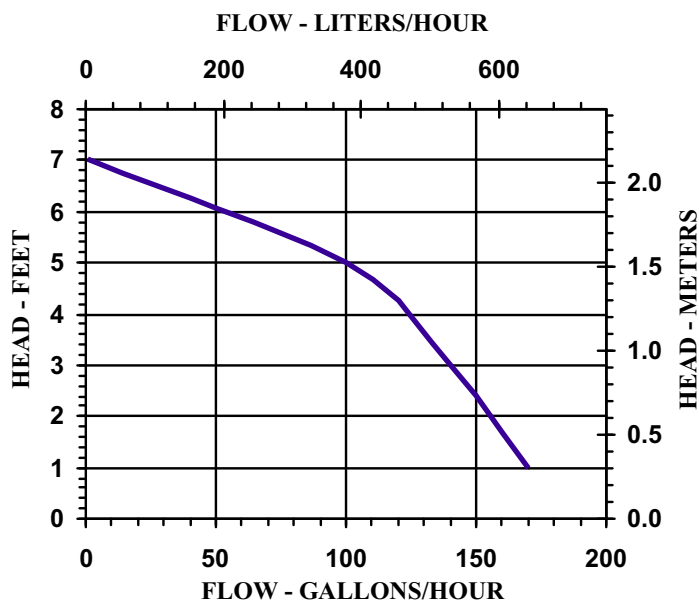

Replacement Parts

Volute	101350
Impeller	101441
Screen	101901
Elbow	943070

Little Giant Pump Co.
 PO Box 12010
 Okla. City, OK 73157
 Phone: 405.947.2511
 Fax: 405.228.1550
www.LittleGiantPump.com