

Little GIANT[®] Pump Company

Eliminator Series
Sump/Effluent Pumps

8E SERIES



Features

Handles liquids and solid waste materials up to 3/4" diameter.

Cast iron pump housing with protective epoxy coating for corrosion resistance

Oil-filled motor housing for lifetime lubrication and rapid heat dissipation

Stainless steel fasteners

Mechanical seals (stainless steel spring, nitrile parts, Carbon and ceramic faces)

Bearings: Upper and Lower Sintered Sleeve

Thermal overload protection

Manual and Automatic models

Automatic operation has 9 to 14 "On" level and 2 to 6 "Off" level range

All 115 volt models are UL/CSA listed.

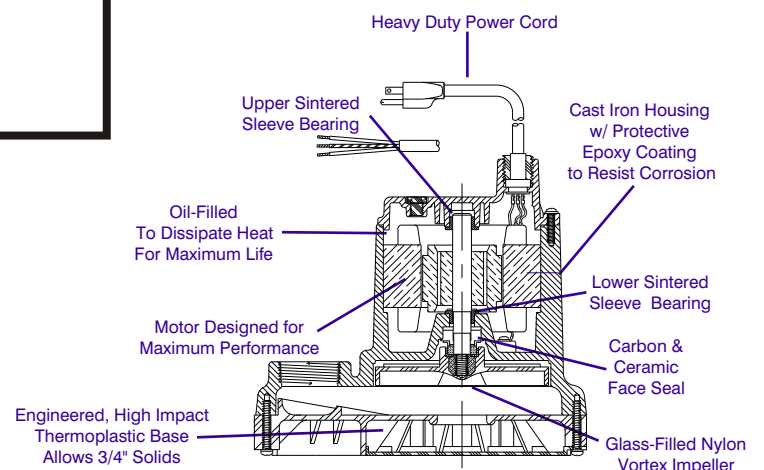

The Model 8E Series De-watering and Effluent pumps are for residential and light commercial use. Pumps feature a 1-1/2" FNPT discharge with a lift of 21', glass-filled nylon cover and ABS base.

Little Giant Pump Co.

8E SERIES SUMP/EFFLUENT PUMP

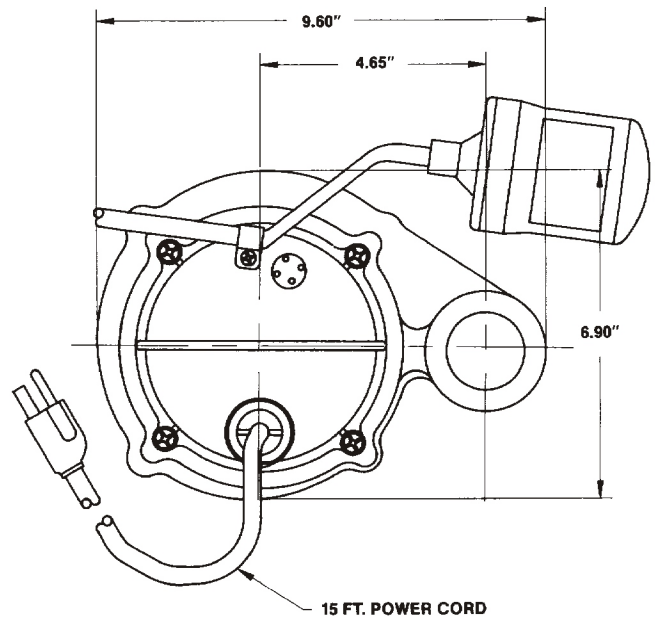
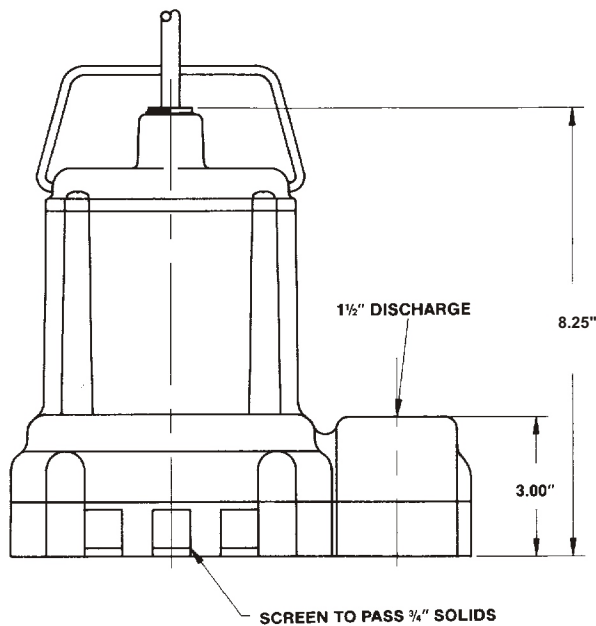

Specifications

MODEL NO.	ITEM NO.	LISTING	HP	VOLTS	SOLIDS SIZE (Dia. In.)	RUNNING AMPS/WATTS	PERFORMANCE (GPM @ HEAD)				SHUTOFF (Ft.)	P.S.I.	PWR. CRD. (Ft.)	WEIGHT (Lbs.)	DIMENSIONS (HxLxW in.)
							5'	10'	15'	20'					
8E-CIM	509000	UL/CSA	1/3	115	3/4	11/900	52	45	33	—	21	9.1	10	24	8.25 x 9.6 x 6.9
8E-CIA-RFS	509100	UL/CSA	1/3	115	3/4	11/900	52	45	33	—	21	9.1	10	25	8.25 x 9.6 x 6.9
8E-CIM	509050	UL	1/3	230	3/4	6/900	52	45	33	—	21	9.1	12	23	8.25 x 9.6 x 6.9
8E-CIM	509005	UL/CSA	1/3	115	3/4	11/900	52	45	33	—	21	9.1	15	24	8.25 x 9.6 x 6.9
8E-CIA-RFS	509105	UL/CSA	1/3	115	3/4	11/900	52	45	33	—	21	9.1	15	26	8.25 x 9.6 x 6.9
8E-CIA-RFS	509120	UL/CSA	1/3	115	3/4	11/900	52	45	33	—	21	9.1	20	26	8.25 x 9.6 x 6.9
8E-CIM	509125	UL/CSA	1/3	115	3/4	11/900	52	45	33	—	21	9.1	25	25	8.25 x 9.6 x 6.9

All models are 60 Hz.

8E SERIES PUMP PERFORMANCE CURVE

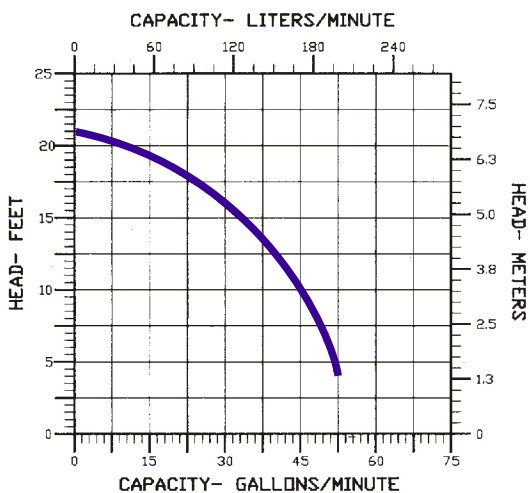

Construction

Motor Housing	Epoxy Coated Cast Iron
Impeller Material	Nylon
Impeller Type	Vortex
Volute	Epoxy Coated Cast Iron
Power Cord	SJTW-A
Mechanical Shaft Seal	Nitrile with carbon and ceramic faces
Fasteners	Stainless Steel
Shaft	Cold Rolled Steel
Bearings	Upper and lower sintered sleeve bearings



Little Giant Pump Co.

PO Box 12010
Okla. City, OK 73157

Phone: 405.947.2511
Fax: 405.951.5674

www.LittleGiantPump.com

Form No. 994340 - 05/01