

AquaLuminator Light and Return Water Flow for Above Ground Pools Owners Manual

IMPORTANT SAFETY INSTRUCTIONS
READ AND FOLLOW ALL INSTRUCTIONS
SAVE THESE INSTRUCTIONS

Table of Contents

SECTION I.	IMPORTANT SAFETY INSTRUCTIONS	2
SECTION II.	LAMP HOUSING INSTALLATION	2
SECTION III.	ELECTRICAL CONNECTIONS FOR STORABLE POOLS	5
SECTION IV.	ELECTRICAL CONNECTIONS FOR PERMANENT POOLS	6
SECTION V.	RELAMPING INSTRUCTIONS	9
SECTION VI.	STORAGE AND WINTERIZING INSTRUCTIONS	10
SECTION. VII.	TECHNICAL DATA.	11
A.	Replacement Parts.	11

WARNING

Before installing this product, read and follow all warning notices and instructions accompanying this light. Failure to follow safety warnings and instructions can result in severe injury, death, or property damage. Call (800) 831-7133 for additional free copies of these instructions.

Important Notice



Attention Installer.

This manual contains important information about the installation, operation and safe use of this product. This information should be given to the owner/operator of this equipment.



Listed

SECTION I. IMPORTANT SAFETY INSTRUCTIONS

When installing and using this electrical equipment, basic safety precautions should always be followed, including the following.

1. This light can be installed on storable above ground or permanent above ground pools.
2. A storable pool has a maximum water depth of 42 inches and is so constructed that it may be readily disassembled for storage and re-assembled to its original integrity.
3. A permanent pool has a maximum water depth of over 42 inches. Do not install on therapeutic pools, hydro-massage bathtubs, spas or hot tubs.
4. To reduce the risk of electric shock, if any cord becomes damaged, return the entire transformer assembly for repair or replacement.
5. Risk of entrapment, injury or death. Use plumbing passageways only to return water to pool. Do not use as a suction device.
6. Risk of electrical shock. Connect only to a grounding type circuit protected by a ground fault circuit interrupter (GFCI). Contact a licensed electrician if you cannot verify that the receptacle or circuit is protected by a GFCI. Do not use an extension cord.
7. Locate your pool so that the wall is at least 10 feet from all electrical receptacles and at least 20 feet from all receptacles not protected by a GFCI. It is also very important to locate the pool so that it is not under any electrical wiring, that is less than 18 feet vertically above the pool wall and within an area located 10 feet outside the pool walls. The pool must also never be located under any lighting fixture or within five (5) feet measured horizontally from any fixture mounted less than five (5) feet vertically above the pool water level.
8. Risk of injury. Install the top of the lens with a minimum of 8 inches and a maximum of 10 inches below top of pool wall or in manufacturers pre-punched return fitting hole.
9. Do not use electrical equipment within 10 feet of pool wall unless specifically U.L. listed for that use.

SECTION II. LAMPHOUSING INSTALLATION

NOTE

Installation of the lamp housing into the pool wall is the same for both the storable and the permanent above ground pools.

1. Remove the bulb retainer nut and push the bulb assembly out from the rear of the fitting body so that it will come out of the front of the fitting. The flow director will come off along with the bulb assembly; see Figure 1. Push the red cap/plug in the end of the bulb assembly. It will be removed later.
2. Unscrew the threaded wall flange from the fitting body by rotating it counter-clockwise.

NOTE

Retain the gaskets supplied and keep them accessible.

3. Use the Teflon™ tape provided. Snugly wrap the threaded wall flange in a clockwise direction (as viewed from the back) starting at the edge of the threads; see Figure 2. Work towards the flange lip (overlapping 1/2 of the tape width with each wrap) then back towards the starting point.
- If you have a new pool, move on to step 10.
 - If the water level is below the return fitting on an existing pool, remove the old fitting and move on to step 10.
 - If the pool is full of water, follow steps 5 through 9.

NOTE

Steps 4 through 8 require two (2) No. 9 winterizing plugs (not supplied).

4. Remove the existing eyeball fitting from the return fitting on your pool wall, see Figure 3.
5. Place a winterizing plug in the front side of the existing return fitting and disconnect the return hose and clamp from the existing fitting.
6. Place a winterizing plug in the front side of the AquaLuminator threaded wall flange
7. While holding the existing return fitting from the inside of the pool, remove the large nut or the existing fitting body on the outside of the pool wall.
8. Using a folded rag in the palm of your hand, push the old return fitting out of the wall from the outside of the pool; see Figure 4. Hold the rag firmly against the wall to prevent water spillage.
9. Insert the flange and gasket from the inside of the pool through the hole cut out for the inlet fitting. Ensure that the threaded wall flange is centered on the hole.
10. Take the remaining gasket and put it on the threaded wall flange from the outside of the pool; see Figure 5. Standard sheet metal walls will have one gasket and one spacer left over. Do not use these two items, as they are for use on narrow interlocking wall panels only.

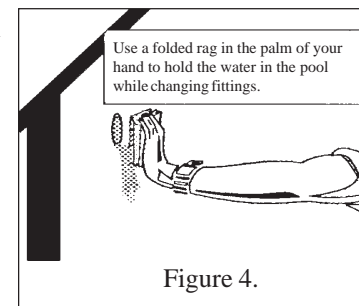
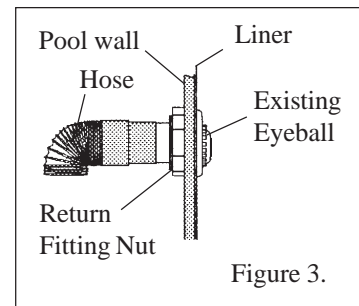
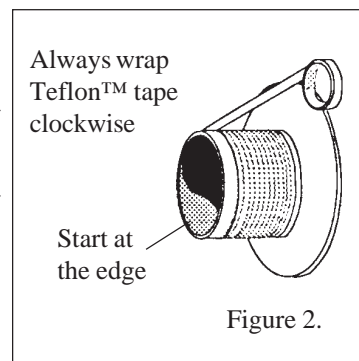
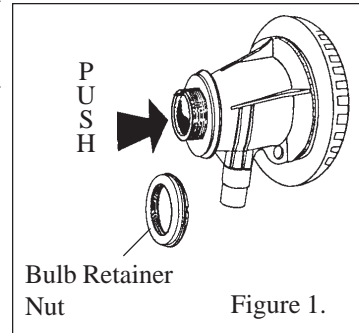

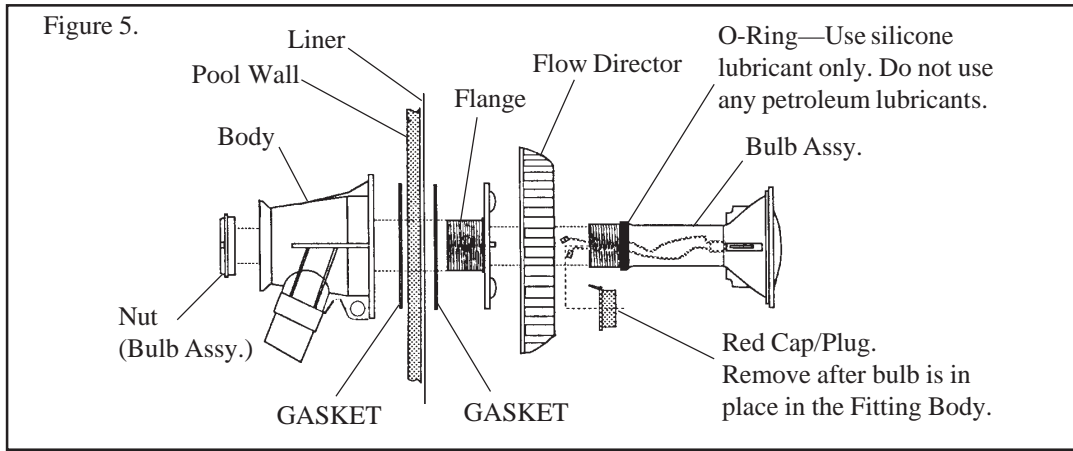

NOTE

For narrow, interlocking, extruded aluminum wall panels, center flange between the ridges while viewed from the inside of the pool. Add the spacer and additional gasket to the flange before inserting the flange through the wall panel. This is necessary to accommodate a fountain attachment.

WARNING

The light fixture must be mounted so that the word "top" is at the top of the fixture when installed. Incorrect orientation and a low water condition can damage the light fixture.

11. With the inlet port of the fitting body in the 3 O'clock position, place the fitting body against the threads of the flange and keeping the inlet port in the 3 O'clock position; see Figure 6. Hand tighten the flange as tight as possible. Rotate the flange, not the body.



CAUTION

Do not over tighten the flange.

12. To complete the tightening process, hold the flange in place and rotate the fitting body until the inlet port is in the 6 o'clock position; see Figure 6.
13. Take a hose clamp and place it over the return hose cuff.
14. Slip the return hose from the equipment, over the inlet port, and tighten the hose clamp securely; see Figure 7.
15. Take the bulb assembly and insert it through the flow director. Note the aligning keyway on the bulb assembly as shown in Figure 8. The keyway must point in the same direction as the top key on the fitting body.

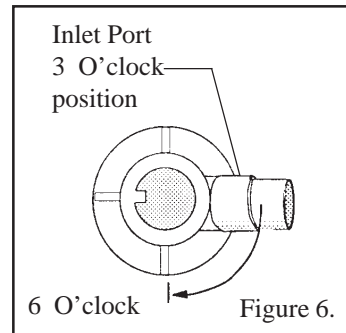

16. Now, from inside the pool, push the bulb assembly and flow director with the red cap/plug in place into the fitting body until the bulb assembly/flow director are nearly flush against the inside pool wall.
17. Thread the bulb assembly nut until it just touches the fitting body, then finger tighten.

	⚠ CAUTION
Do not over tighten as adjustability of the flow director may be impaired and/or damage to parts causing leakage may occur. If the flow director does not rotate by hand, the nut is too tight.	

18. Take the red cap/plug off and gently bring the wire connectors through the back side of the bulb assembly. Save the red cap/plug for storage and winterizing.

	⚠ CAUTION
This lighting fixture may be damaged if subjected to freezing weather. See winterizing instructions for details on how to store the bulb assembly.	

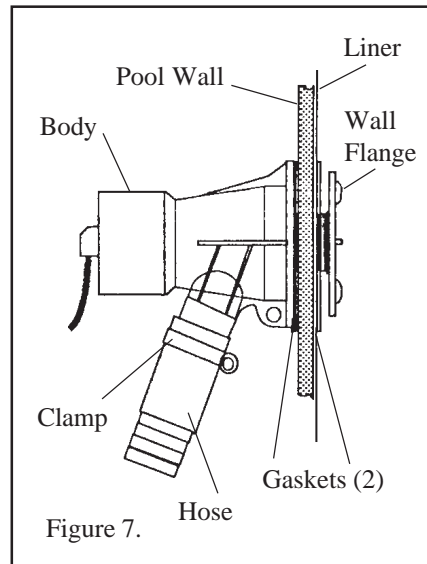

SECTION III. ELECTRICAL CONNECTIONS FOR STORABLE POOLS

1. Connect the wire connectors from the bulb assembly to the wire connectors attached to the snap-on cord cap.

NOTE

There is no polarity (no positive or negative) to the wires, either connection will work.

2. Snap the cap onto the end of the body and turn so that the electrical cord is pointing down.
3. Mount the transformer on the vertical wall using the single screw provided.
4. Plug the power cord's 3-prong plug into an appropriate 110V GFCI protected receptacle at least 10 feet from the pool.
5. If the light is not on, press the switch on the transformer case *once*.

⚠ WARNING	
	Risk of electric shock. Connect only to a grounding-type receptacle protected by a GFCI. Do not use extension cords for connection. Failure to do so can result in death or severe personal injury.

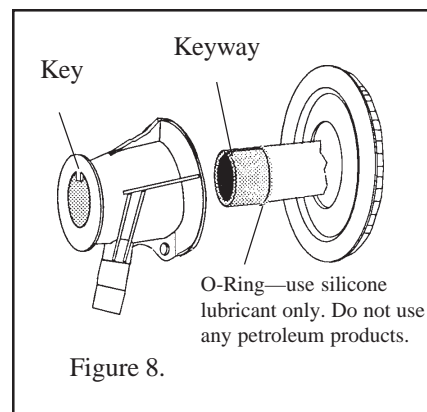

WHAT IS A GFCI???

A 'Ground Fault Circuit Interrupter' is an electrical safety device designed to measure electrical leakage in a circuit. It is far more sensitive than a standard circuit breaker. GFCI equipped breakers and outlet combinations react to unsafe leakage and shut the power off before electrical shock injury can occur. Any electrical device used within 10 feet of a pool must be protected by a GFCI equipped outlet or a GFCI equipped circuit breaker and be intended for such use.

SECTION IV. ELECTRICAL CONNECTIONS FOR PERMANENT POOLS

NOTE

To install the transformer assembly for permanent above ground pools, several modifications must be completed.

⚠ WARNING



Disconnect all power before cutting cords to length. Failure to do so could result in personal injury and/or death.

This installation requires cutting the two cords to specified lengths.

Risk of electrical shock. Permanent installations must be performed by a licensed electrical professional in accordance with the National Electrical Code and any Local Codes that apply. Failure to do so could result in personal injury and/or death.

1. Identify the cord from the transformer assembly to the snap-on cord cap and cut it at a distance of five (5) feet from the transformer assembly; see Figure 9.
2. Strip a 2 inch section of the outer insulation jacket from the cord. This will expose the two insulated conductors of the cord; see Figure 10.
3. Remove the strain relief and the snap-on cord cap from the cut section of cord. To remove the strain relief it is necessary to use a pair of strain relief pliers; if these are not available, then a pair of needle-nose pliers can be used. Compress the lower tab against the upper part of the strain relief from the inside of the cap while pushing the cord and the strain relief through the cap; see Figure 11.
4. Route cord through the cord hole in the body; see Figure 12.

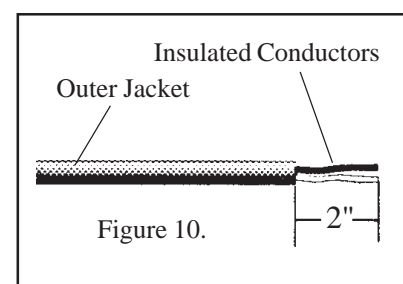
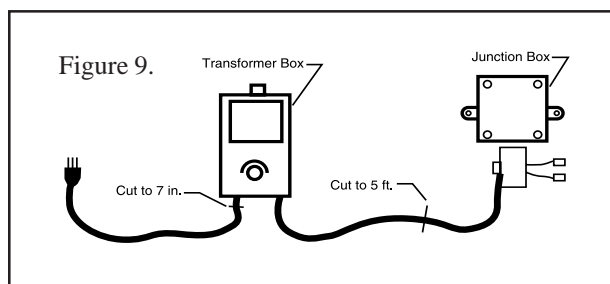

⚠ WARNING



Do not attach or hang anything but this cord from the cord cap through the hole in the body to the transformer housing. Attaching or hanging items from this location can result in failure to the body or the pool wall which can result in serious personal injury and/or property damage.

5. Reinstall the snap-on cord cap to the stripped end of the cord leaving 1/4 inch black insulation protruding into the cap with the strain relief positioned as illustrated in Figure 13.

NOTE

Strain relief must be reinstalled at the end of the outer insulation jacket. This will leave the two insulated conductors extending from the inside of the snap end of the cord cap.

6. Strip the insulation back 1/4 inch on the two insulated conductors and install the two wire connectors provided into the end of each insulated conductor using a crimping pliers.
7. Connect the wire connectors from the bulb assembly to the wire connectors attached to the snap-on cord cap.

NOTE

There is no polarity (no positive or negative) to the wires, either connection will work.

8. Snap the cap onto the end of the body and turn so that the electrical cord is pointing down.
9. Cut off the cord with the 3-prong plug seven (7) in. from where it exits the transformer box; see Figure 9. Discard the remaining cord and plug.
10. Insert the cord from the plug through the smooth hole and then insert the cord through the threaded hole. Slide the cord from the light assembly into the angled slot on the junction box bottom. Make sure the cord by the transformer box starts by the deep end of the angled slot; see Figure 14.

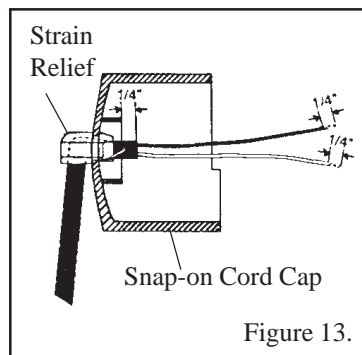
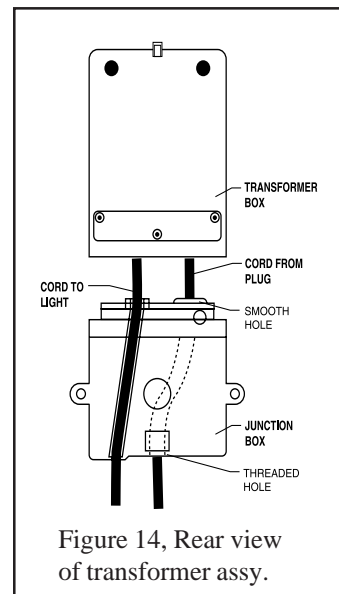
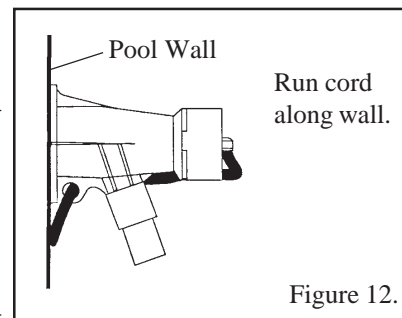
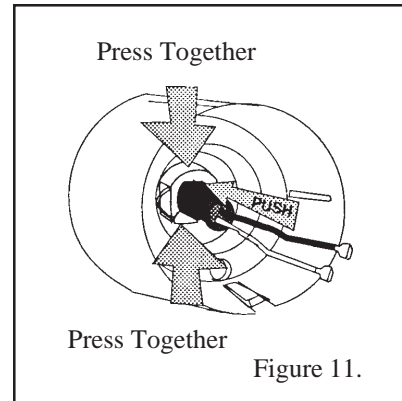

Figure 13.



11. Place the junction box cover on the junction box bottom so that the junction box can more easily snap into the transformer box; see Figure 15. Snap the pieces together, then remove junction box cover.
12. Mount the transformer box on a pool support approximately 18 inches above the ground, in a position accessible to electrical connection; see Figure 16. To mount the transformer junction box, insert one of the screws provided, to a pool support.

NOTE

Do not install the transformer directly onto the pool wall.

13. Pull cord out of the junction box and strip a six (6) inch section of the outer insulation jacket from the cord, see Figure 17.

⚠ WARNING



Risk of electric shock. Connect only to a circuit protected by a GFCI. Failure to do so can result in serious personal injury and/or death.

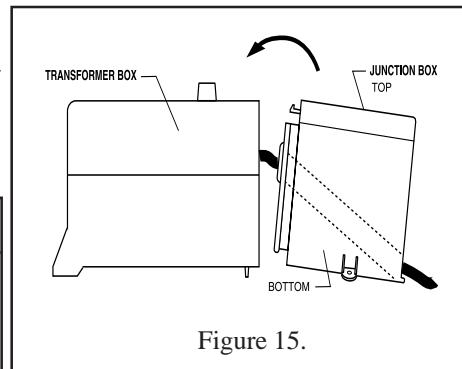

Figure 15.

14. Connect the conduit to the junction box. Make electrical connections in the junction box. Reinstall the cover to the junction box.
15. Using the cable clamp provided, attach the cable clamp to the cord and mount the cable clamp to the pool support, see Figure 18, so that the cord lies flush against the pool wall. Do not attach directly to the pool wall. This will keep the cord flush to the wall; see Figure 19.
16. Make electrical connections to the power supply protected by a GFCI. Turn on the power.
17. If the light is not **ON**, press the switch on the transformer case **once**.

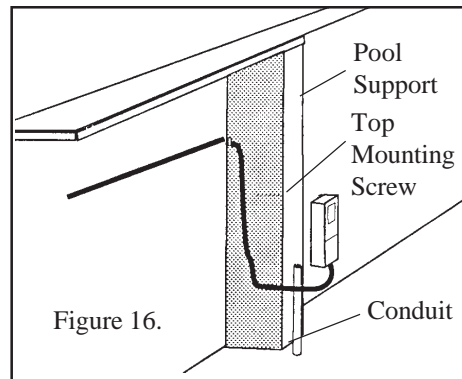

Figure 16.

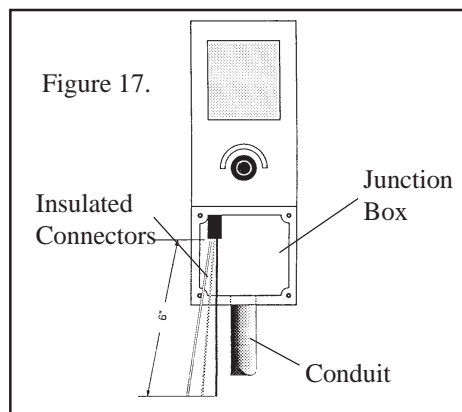

Figure 17.

SECTION V. RELAMPING INSTRUCTIONS

WARNING



Risk of electric shock. Disconnect power before servicing this unit. Failure to disconnect power can result in death or severe personal injury.

1. It is desirable to reduce the water level to the lower edge of the flow director. This makes bulb assembly replacement easier, but it is not mandatory.
2. Remove power from the unit by taking the power cord's 3-prong plug and disconnecting it from its electrical outlet, or in the case of a hard-wired application, by turning the respective circuit breaker to the OFF position.
3. Remove the snap-on cord cap by inserting a slotted screw driver into the access hole as illustrated in Figure 20 and prying upwards.
4. Disconnect both wire connectors and put the snap-on cord cap aside in a dry location and remove the bulb assembly nut.
5. At this point you should have the new replacement bulb assembly accessible and confirm that the red cap/plug is pressed firmly into the bulb assembly to prevent water from entering the bulb assembly.
6. If you were able to lower the water level as suggested in step 1, then simply remove the old bulb assembly by pulling on the flow director while pushing the bulb assembly from the outside of the pool. If you were unable to lower the water level, follow these instructions: push the bulb assembly out from the outside of the pool, keeping the back of the fitting covered with a folded rag in the palm of your hand to prevent water loss from the rear of the fitting body; see Figure 4. Pull the flow director and bulb.

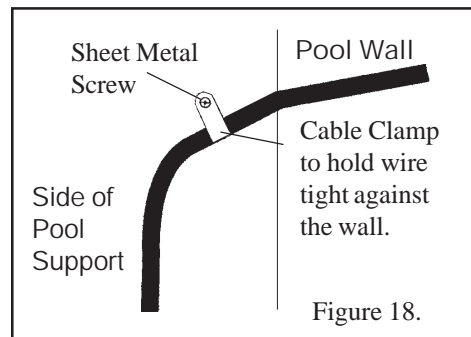

6. If you were able to lower the water level as suggested in step 1, then simply remove the old bulb assembly by pulling on the flow director while pushing the bulb assembly from the outside of the pool. If you were unable to lower the water level, follow these instructions: push the bulb assembly out from the outside of the pool, keeping the back of the fitting covered with a folded rag in the palm of your hand to prevent water loss from the rear of the fitting body; see Figure 4. Pull the flow director and bulb.
7. Take the new replacement bulb assembly with the red cap/plug in place and insert the bulb assembly through the flow director. Note the aligning keyway on the bulb assembly as shown in Figure 8. The keyway must point in the same direction as the top key on the fitting body.

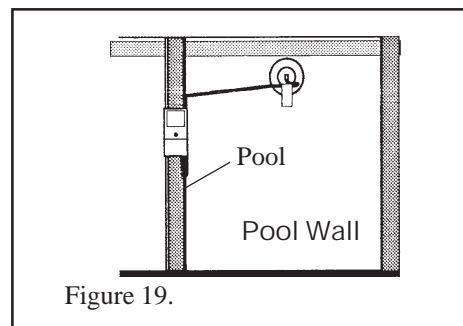

7. Take the new replacement bulb assembly with the red cap/plug in place and insert the bulb assembly through the flow director. Note the aligning keyway on the bulb assembly as shown in Figure 8. The keyway must point in the same direction as the top key on the fitting body.

Now, from inside the pool, push the bulb assembly with the flow director into the fitting body until both are nearly flush against the inside pool wall. You can now remove your hand and the fitting should again be sealed.

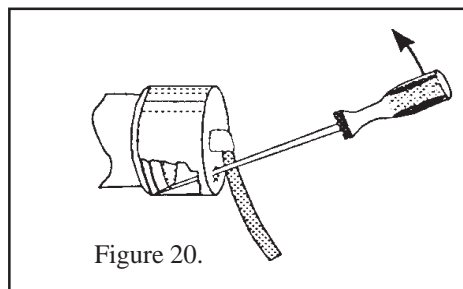

- Thread the bulb assembly nut until it just touches the fitting body, then finger tighten.

	⚠ CAUTION
	Do not over tighten as adjustability of flow director may be impaired and/or damage to parts causing leakage may occur. If flow director does not rotate by hand, nut is too tight.

- Take the red cap/plug off and gently bring the wire connectors through the back side of the bulb assembly. Save red cap/plug for storage and winterizing.
- Connect the wire connectors from the bulb assembly to the wire connectors attached to the snap-on cord cap.

NOTE

There is no polarity (no positive or negative) to the wires, either connection will work.

- Snap cap onto end of body and turn so that the electrical cord is pointing down; see Figure 12.

⚠ WARNING	
	Risk of electric shock. Connect only to a circuit protected by a GFCI. Failure to do so can result in death and/or serious injury.

- Reconnect the power to a circuit in accordance with the appropriate electrical connections. See Sections III and IV, Electrical Connections. If the light is not on, press the switch on the transformer case *once*.

⚠ WARNING	
	This is an electrical appliance. Unsupervised use of this product by children can result in injury and/or death.

SECTION VI. STORAGE AND WINTERIZING INSTRUCTIONS

- It is common practice to drain the water level to a point below the skimmer and the light, for winterizing.
- For storable pools:** remove power from the unit by taking the power cords' three-prong plug and disconnecting it from its electrical outlet.
For permanent pools: turn off all electrical power supplying the light circuit at the main circuit breaker.
- Remove the snap-on cord cap by inserting a slotted screwdriver into the access hole and prying upwards, as illustrated in Figure 20 in the relamping instructions.
- The wire connectors should be gently disconnected and pushed into the rear of the bulb assembly.
- Push red cap/plug into rear of bulb assembly to seal it.
- Remove the bulb assembly nut.

- Remove the bulb assembly by pulling on the flow director while pushing the bulb assembly from the outside of the pool.

NOTE

The fitting body, threaded wall flange and gaskets may remain attached to the pool wall when winterizing, but should be removed if pool is to be stored.

- For storable pools:** remove the transformer from its mounting by lifting up and out.

For permanent pools: cover the cord cap on the end of the flexible cord with a plastic bag and seal with a twist tie or rubber band. Wrap the cord into a coil, cover with a plastic bag and seal. Elevate cord to prevent contact with ground moisture.
- Place all the parts together in a box and store indoors.

When reinstalling bulb assembly next season do not use petroleum base product.

CAUTION	
	<p>Do not use any petroleum base lubricant. Petroleum base products will destroy plastic parts. Lubricate o-ring with a silicone lubricant only. A new o-ring should be used each time the bulb assembly is removed.</p>

SECTION.VII. TECHNICALDATA.

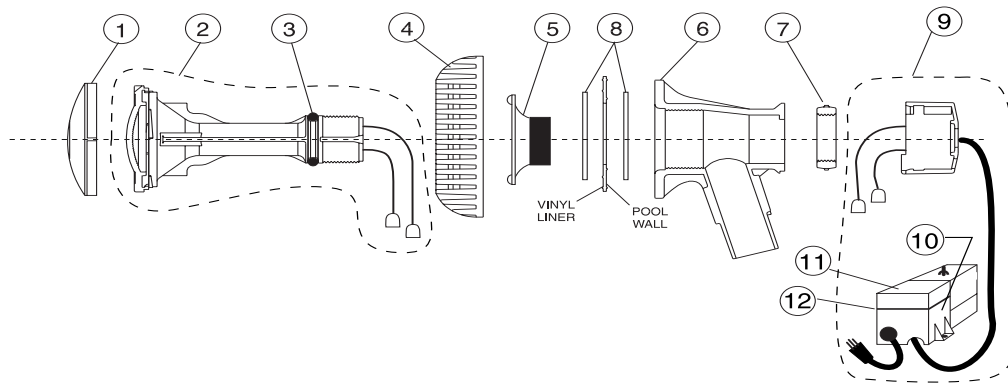

- | | |
|-----------------------------------|---|
| 1. 79123401 Lens, 'Luxury', blue | 8. 79116800 Gasket (2) |
| 1. 49300000 Lens, 'Luxury', red | 9. 83000000 Trans./J-Box Assy. w/snap-on cord cap |
| 2. 69100000 Bulb Assembly | 79110700 Spacer, Mounting |
| 3. 79116900 O-ring | 10. 78800100 J-Box Bottom |
| 4. 79102800 Flow Director | 11. 87370000 J-Box Top |
| 5. 79118300 Wall Flange, Threaded | 12. 79401000 J-Box Gasket |
| 6. 79126900 Fitting Body | |
| 7. 79116600 Nut | |

Pentair Pool Products AquaLuminator™ Limited Warranty

Pentair Pool Products manufactures the AquaLuminator™ under the highest standards of workmanship using quality materials. Accordingly, Pentair Pool Products expressly warrants these products as follows:

WARRANTY COVERAGE—All equipment actually manufactured by Pentair Pool Products is warranted to be free from defects in material and/or workmanship for a period of one year from the date of purchase.

EXCLUSIONS FROM THIS WARRANTY—This warranty does not cover:

1. Any items manufactured by other companies and installed by Pentair Pool Products. Such items may carry warranties offered by the original manufacturers.
2. Problems resulting from failure to comply with installation instructions or drawings, or improper installation. Damage caused by installer.
3. Problems resulting from abuse, misuse, negligence or accident by any party other than Pentair Pool Products.
4. Problems resulting in whole or in part from alteration or modification of these products by any party.
5. Metal failures due to chemical corrosion.

WARRANTY OBLIGATIONS OF PENTAIR POOL PRODUCTS—Should a defect in workmanship and/or material in any item covered by this warranty become evident during the term of the warranty, then upon the consumer following the procedures set forth below, Pentair Pool Products will, at its option, repair or replace such item at its own cost and expense. Pentair Pool Products is not, however, responsible under this warranty for any cost of shipping or transportation of the equipment or parts thereof to or from the Service

Department. Also, Pentair Pool Products is not liable for any loss of time, inconvenience, incidental expenses such as telephone calls, labor or material charges incurred in connection with the removal or replacement of the equipment, or any other incidental or consequential damages.

PLEASE NOTE: Some states do not allow the exclusion or limitation of incidental or consequential damages, so the above limitation or exclusion may not apply to you.

PROCEDURE FOR OBTAINING WARRANTY PERFORMANCE—In order to obtain the benefits of this warranty, the consumer who made the original retail purchase shall contact Pentair Pool Products, Consumer Relations Department, 10951 West Los Angeles Ave., Moorpark, CA 93021, as soon as possible after discovery of the defect, but in no event later than the expiration date of the warranty period provided in this warranty. Upon receipt of this communication, Pentair Pool Products will promptly notify the consumer of the address to which the defective item may be shipped. The consumer shall then ship the item, freight prepaid, to the address indicated together with a letter stating the model number, serial number, if any, and date of purchase of the item which is claimed to be defective, the name and address of the consumer, and a brief description of the problems encountered.

WARRANTY PROTECTS ORIGINAL RETAIL PURCHASER — This warranty extends to the consumer who made the original retail purchase only and is not enforceable by any other party.

WARRANTIES OR REPRESENTATIONS BY OTHER — No dealer or other person has any authority to make any warranties or representations concerning Pentair Pool Products or its products. Accordingly, Pentair Pool Products is not responsible for any such warranties or representations.

OTHER RIGHTS — This warranty gives you specific legal rights, and you may also have other rights which vary from state to state.

Pentair Pool Products

1620 Hawkins Rd., Sanford, NC 27330 • (919) 774-4151
10951 West Los Angeles Ave., Moorpark, CA 93021 • (805) 523-2400



SAVE THESE INSTRUCTIONS.