

# STA-RITE®

## MODULAR DE FILTERS

O W N E R ' S M A N U A L

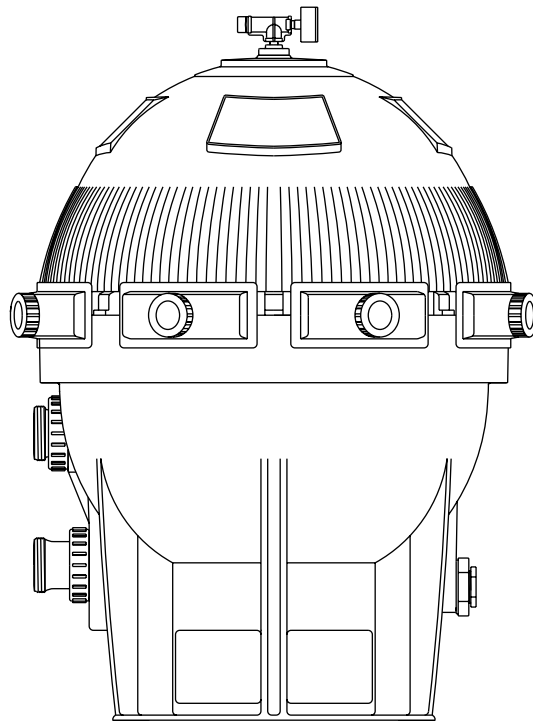

INSTALLATION, OPERATION & PARTS

### MODELS

S7MD60

S7MD72

E  
N  
G  
L  
I  
S  
H

F  
R  
A  
N  
Ç  
A  
I  
S

E  
S  
P  
A  
Ñ  
O  
L



This manual should be furnished to the end user of this filter; its use will reduce service calls and chance of injury and will lengthen filter life.

### Sta-Rite Pool/Spa Group

293 Wright Street, Delavan, WI 53115

International: 262-728-5551, FAX: 262-728-7550

[www.starite.com](http://www.starite.com)

Union City, TN • Delavan, WI • Mississauga, Ont. • Murrieta, CA

© 2004, Sta-Rite Industries

Printed in U.S.A.

S596 (Rev. 1/19/04)

# MODULAR DE FILTERS

To avoid unneeded service calls, prevent possible injuries, and get the most out of your filter, READ THIS MANUAL CAREFULLY!

## The Sta-Rite System 3 Modular DE Filter:

- Is designed to filter water for swimming pools.
- Is an excellent performer; durable, reliable.

## Table of Contents

Safety Instructions .....	3
General Information .....	4
Installation .....	5
Specifications .....	6
Initial Startup .....	7
Filter Disassembly / Assembly .....	8
Cleaning the Filter .....	9
Filter Backwash Procedure .....	9
Module Cleaning Procedure .....	10
Special Cleaning Instructions .....	11
System Inspection .....	11
Winterizing .....	12
Troubleshooting Guide .....	13
Repair Parts List .....	14
Warranty .....	16



## READ AND FOLLOW SAFETY INSTRUCTIONS!

**⚠** This is the safety alert symbol. When you see this symbol on your filter or in this manual, look for one of the following signal words and be alert to the potential for personal injury.

**⚠ DANGER** warns about hazards that **will** cause death, serious personal injury, or major property damage if ignored.

**⚠ WARNING** warns about hazards that **can** cause death, serious personal injury, or major property damage if ignored.

**⚠ CAUTION** warns about hazards that **will** or **can** cause minor personal injury or property damage if ignored.

**NOTICE** indicates special instructions not related to hazards.

**Carefully read and follow all safety instructions in this manual and on equipment.** Keep safety labels in good condition; replace if missing or damaged.

**⚠ WARNING** **Hazardous pressure. Incorrectly installed or tested equipment may fail, causing severe injury or property damage.** Read and follow instructions in owner's manual when installing and operating equipment. Have a trained pool professional perform all pressure tests.

1. Do not connect system to a high pressure or city water system.
2. Use equipment only in a pool or spa installation.
3. Trapped air in system can cause explosion. BE SURE all air is out of system before operating or testing equipment.
4. DO NOT pressure test with compressed air!

**Before pressure testing, make the following safety checks:**

- Check all clamps, bolts, lids, and system accessories before testing.
- Release all air in system before testing.
- Tighten Sta-Rite trap lids to 30 ft. lbs. (4.1 kg-cm) torque for testing.
- Water pressure for test must be less than 25 PSI (172 kPa).
- Water Temperature for test must be less than 100° F. (38° C).
- Limit test to 24 hours. After test, visually check system to be sure it is ready for operation. Remove trap lid and retighten hand tight only.

**NOTICE:** These parameters apply to Sta-Rite equipment only. For non-Sta-Rite equipment, consult equipment manufacturer.

	<b>⚠ WARNING</b>	<b>BEFORE WORKING ON FILTER:</b>
	If filter clamps are adjusted or removed under pressure, tank may explode, causing severe injury or major property damage.	<ol style="list-style-type: none"> <li>1. Stop pump.</li> <li>2. Open air release valve.</li> <li>3. Release all pressure from system.</li> </ol>
	<b>⚠ WARNING</b>	<b>BEFORE WORKING ON PUMP OR MOTOR</b>
	Filter pumps require hazardous voltage which can shock, burn, or cause death.	Disconnect power to motor at main circuit breaker. Discharge motor capacitor to ground.

## GENERAL INFORMATION

- Clean a new pool as well as possible before filling pool and operating filter. Excess dirt and large particles of foreign matter in the system can cause serious damage to the filter and pump.
- With a diatomaceous earth (DE) filter system in place and operating correctly, clean water is returned to the pool faster than pool water is being contaminated. A typical pool installation will require approximately one week to obtain and maintain the sparkle that your filter is capable of giving you.
- DO NOT use more than the recommended amount of DE in your filter. To do so can cause a buildup of DE and "bridging" between the elements which will plug the filter.

**⚠ If filter is improperly disassembled or assembled, it can explode under pressure! To avoid danger of severe injury or major property damage, always follow service instructions in this manual when working on filter!**

### **⚠ WARNING**

**Hazardous pressure.  
Can cause severe  
injury or major  
property damage  
from tank blow up.**

Release all pressure  
and read instructions  
before working on filter.

**⚠ NEVER operate this filter system at more than 50 pounds per square inch (50 PSI/345kPa) pressure! Be sure filter pressure gauge operates when system is operating. If pressure gauge is damaged or does not work, replace it.**

**⚠ Purge all air from system before operating system. NEVER operate filter with air trapped inside.**

- On a new pool installation, we recommend:
  1. Disassemble the filter after the initial cleanup.
  2. Remove and hose down the module to remove contaminants.
- It is a good idea to remove the module once a year and soak it in a filter cleaning solution to remove accumulated body oils, etc.; see Page 11, "Special Cleaning Instructions".
- Cleaning interval is based on pressure differential, not on length of time filter is operated. Different water conditions will have different normal cleaning intervals. If backwashing filter is not possible, use "Module Cleaning Procedure", Page 10, at regular intervals to clean filter.
- Check local codes for restrictions on backwash to waste piping, separation tank requirements and spent D.E. disposal requirements.

# INSTALLATION

Installation of filter should only be done by qualified, licensed personnel.

## Filter mount must:

- Provide weather and freezing protection.
- Provide space and lighting for easy access for routine maintenance. (See Figure 1 and Table II, Page 6, for space requirements.)
- Be on a reasonably level surface and provide adequate drainage.
- Be as close to pool as possible to reduce line loss from pipe friction.

## Piping:

- Piping must conform to local/state plumbing and sanitary codes.
- Use Teflon tape or Plasto-Joint Stik' on all male connections of plastic pipe and fittings. **DO NOT use pipe compounds on plastic pipe; it will cause the pipe to crack. Do not use sealant on unions—assemble them dry and hand tight.**

- Support pipe independently to prevent strains on filter or valve.
- Use 2" (51mm) pipe to reduce pressure losses as much as possible.

**NOTICE:** Filter may be located away from pool, but for adequate flow larger pipe may be needed. Check local codes for remote installation.

- Fittings restrict flow; for best efficiency use fewest possible fittings.
- Keep piping tight and free of leaks: pump suction line leaks may cause trapped air in filter tank or loss of prime at pump; pump discharge line leaks may show up as dampness or jets of water.
- **NOTICE:** Overtightening can crack filter ports.

## Valves:

- A check valve installed ahead of filter inlet will prevent contaminants from draining back into pool.
- A check valve installed between filter and heater will prevent hot water from backing up into filter and deforming internal components.
- For installation allowing backwashing, install Sta-Rite Two Position Slide Valve or Multiport Selector Valve with filter. See Table I. If you intend to clean your filter according to "Module Cleaning Procedure", Page 10, no slide or multi-port valve is required. See Figures 1 and 2, Page 6, for correct water flow when connecting pipe.
- Filter ports and valve ports are furnished with union connections. **DO NOT use pipe sealants on union collar (nut).**
- Use care before assembly not to damage union sealing surfaces or O-Ring.
- To allow recirculation during precoat (if precoat pot is used), install a recirculation line with shut-off between pad return line and pump suction.

## Electrical

- All wiring, grounding and bonding of associated equipment must meet local and/or National Electrical Code standards.

**TABLE I - Sta-Rite valves for use with Model S7MD60 and S7MD72 filters**

Port Size	Part Number
2"	<b>Multi-port</b> 18201-0300
2"	<b>Plastic Slide</b> 14935-0300

**NOTICE:** Use of valves other than those listed above could cause reversed water flow through filters and damage to internal filter components.

<sup>1</sup> Lake Chemical Co., Chicago, IL

# SPECIFICATIONS

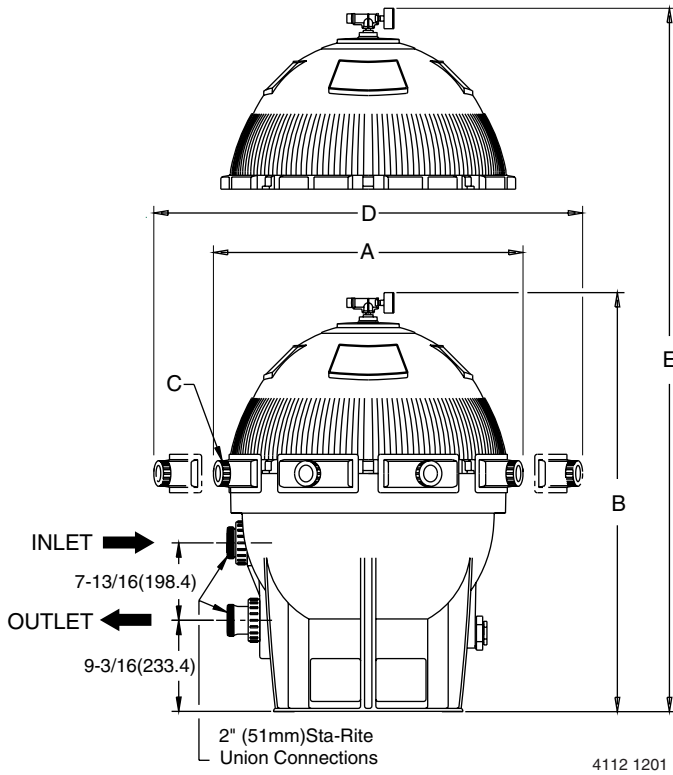

FIGURE 1 – Dimensions in inches (mm)

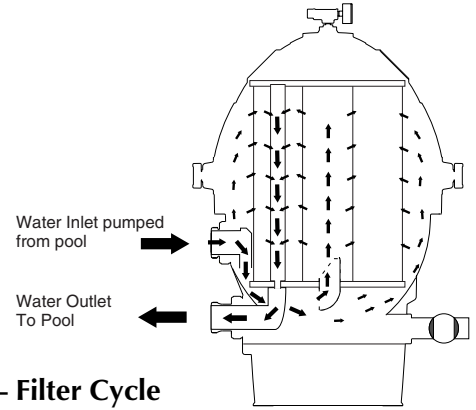

Figure 2 – Filter Cycle

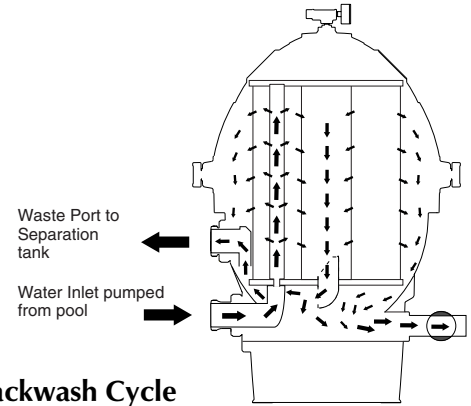
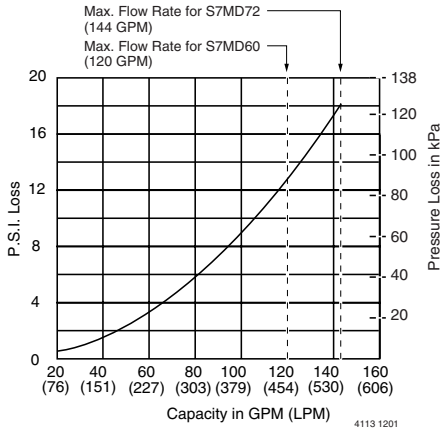

Figure 3 – Backwash Cycle



Pressure Drop Curve

TABLE II - SPACE REQUIREMENTS IN INCHES (MM)

A	B	C*	D	E
28½(724)	42(1067)	7	36(914)	53½(1359)

\* Number of clamps.

TABLE III - APPROVED DE

Use only the following DE or equal:

Johns Manville	Celite 545
GREFCO	Dicalite 4200
Eagle-Picher	Celatom

TABLE IV - FILTER SPECIFICATIONS & OPERATING INFORMATION

Filter Model:	S7MD60	S7MD72
Filter Area in Sq. Ft. (M²)	60 Sq. Ft. (5.57)	72 Sq. Ft. (6.69)
Lbs. (Kg) of D.E. Used	9.0 (4.1)	11.0 (5.0)
Max. Flow Rate in GPM (LPM)	120 (454)	144 (545)
NSF Public Pool Flow Rate in GPM (LPM)	120 (454)	144 (545)
Max. Operating Pressure in PSI (kPa)	50 (345)	50 (345)

**NOTICE:** 1/2 pound of DE will fill a one-pound coffee can.



## INITIAL START-UP

**⚠** Be sure pump is OFF before starting procedure.

**⚠** Do not operate these filters at more than 50 PSI (345 kPa) under any circumstances!

**⚠ CAUTION** To prevent serious damage to the module fabric, NEVER run your DE filter without a diatomaceous earth precoat!

**⚠ CAUTION** To avoid damage to internal filter components, never change handle position on control valve while pump is running.

1. Make sure all clamps are in place and knobs are securely hand-tight.
2. Set valve to 'filter' position.
3. Fill trap on pump with water.
4. Open air release valve on top of filter assembly (Key No. 3, Page 14).
5. Start pump to purge air from system.
6. When steady stream of water comes from air release valve, close the valve.
7. To prepare precoat slurry, mix diatomaceous earth (DE) and water. See Table IV or instruction decal on filter shell for amount of DE to use.
8. Empty slurry slowly into skimmer to precoat filter element with an even filtering cake.

**⚠** Close valve before air is drawn into system.

**NOTICE:** To avoid clogging the filter, do not use more DE than is specified in Table IV.

After filter is operating, record filter pressure gauge reading in owner's manual for future reference on when to clean filter.

**NOTICE:** When installed on a new pool, after approximately 48 hours of operation disassemble filter and clean out accumulated debris (see "Module Cleaning Procedure", Page 10).

**⚠** To avoid severe injury or major property damage, exactly follow instructions under "Filter Disassembly/Assembly" (Page 8)!

## FILTER DISASSEMBLY/ ASSEMBLY PROCEDURE

**CAUTION** To avoid equipment damage and personal injury, never change handle position on control valve while pump is running.

### BEFORE DISASSEMBLING FILTER:

- 1. STOP PUMP.**
- 2. OPEN** air release valve and drain fitting.
- 3. WAIT** until all pressure is released and water drained from filter tank and system before loosening clamp knobs.

### Disassembly:

- Backwash filter according to instructions under "Filter Backwash Procedure", Page 9.
- Stop pump.
- Open air release valve (Key No. 3, Page 14) on top of filter tank to release all air pressure from inside of tank and system.
- Remove filter drain plug and drain all water from tank.
- To equalize flange stresses, loosen clamp knobs alternately (that is, on opposite sides of tank) around tank. Remove clamps.
- Being careful not to damage tank O-Ring (Key No. 8, Page 14), lift upper tank shell (Key No. 7, Page 14) off lower tank shell (Key No. 21, Page 14).

### Assembly:

- Remove O-Ring slowly to avoid stretching or tearing it.
- Inspect tank O-Ring (Key No. 8, Page 14) for cuts, nicks, etc. If O-Ring is damaged, deformed, or has lost its resiliency, replace with a new one.
- Clean O-Ring area of tank shell (both halves) and O-Ring.
- Carefully install O-Ring and upper tank shell (Key No. 7, Page 14) on tank bottom (Key No. 21, Page 14).

**NOTICE:** Do not lubricate O-Ring. Lubricants attract dirt and grit and may (especially when petroleum based) damage O-Ring and void warranty.

**NOTICE:** Be sure upper tank shell contacts O-Ring surface evenly and seal area is clean and free from dirt.

- Install clamp bolts and clamps. Do not tighten clamps yet.
- See Figure 4 for clamp tightening sequence. Tighten all clamp knobs securely hand tight.

**NOTICE:** To equalize stresses on tank, be sure to tighten clamps in sequence shown. DO NOT work your way around the filter tightening adjacent clamps.

- Install air relief valve and gauge assembly on tank.

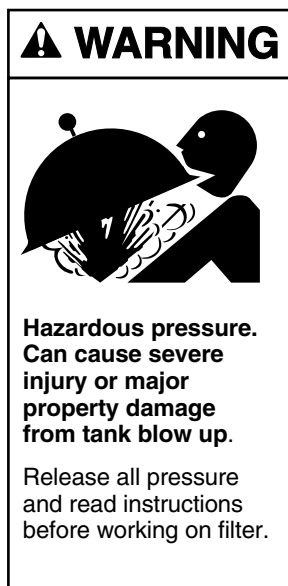



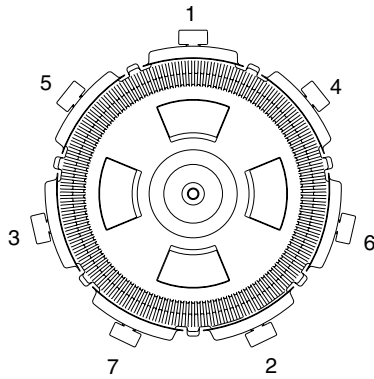

**FIGURE 4 - 21" Filter clamp tightening sequence.**

## CLEANING THE FILTER

### When to Clean:

**NOTICE:** If installation does not allow backwashing, use module cleaning procedure regularly (see Page 10).

1. With a new filter:
  - A. Record filter operating pressure at startup. When pressure reaches 10 PSI (69kPa) above startup operation pressure, stop pump for 30-60 seconds to allow filtering cake to release.
  - B. Restart pump to form new cake. Pressure should now be less than 10 PSI (69kPa) above startup operating pressure.
  - C. If pressure is still more than 10 PSI (69kPa) above startup operating pressure, backwash filter (see below).
2. Thoroughly clean air bleed assembly (Key No. 9B, Page 14) on top of filter module EVERY time filter is opened. Be sure to remove all debris from screen. Replace screen if damaged.
3. At least twice a year, manually clean filter module according to instructions, Page 10. At least once a year, follow instructions under "Special Cleaning Instructions", Page 11, as well.

### Filter Backwash Procedure:

**▲ CAUTION** To prevent equipment damage and possible injury turn pump OFF before changing valve position.

**NOTICE:** Before backwashing with a separation tank, review separation tank owner's manual for instructions.

1. Stop pump.
2. Change valve position.
  - A. If using Multi-port Valve, set it to backwash position.
  - B. If backwashing with a Two Position Slide Valve, push handle to full down position.
3. Start pump and run it for 3 minutes.
4. Stop pump and open tank bottom side drain.
 

**NOTICE:** A 1-1/2" drain valve is recommended.
5. Start pump and run 1 minute, backwashing through filter valve and tank drain.
6. STOP PUMP, return filter valve to filter position and close tank drain.
 

**NOTICE:** Do not vacuum pool while backwashing filter.
7. Compare pressure reading on gauge with reading recorded after initial startup. The two readings should be very close; if not, do "Module Cleaning Procedure", Page 10.

## **⚠ WARNING**

**Hazardous pressure.  
Can cause severe  
injury or major  
property damage  
from tank blow up.**

Release all pressure  
and read instructions  
before working on filter.

### **When to Clean the Filter**

The filter module should normally be cleaned when the pressure gauge reading increases 10 PSI over the start-up pressure (record the start-up pressure in a convenient place).

In some pools, accessories such as fountains or pool cleaners may be noticeably affected by the normal decrease in flow as the filter becomes dirty. If so, clean the filter more frequently (that is, at a pressure increase of less than 10 PSI) in order to maintain the required flow.

### **Recommended Specialty Filter Cleaners**

Filter Cleanse™,  
Great Lakes Biochemical

BIOGUARD Strip Kwik™,  
BIOGUARD KleenIt™, Softswim®  
Filter Cleaner,\*\*  
BIOLABS, Inc.

Filter Kleen™,  
Haviland Products Co.

BAQUA CLEAN™, \*\*  
Zeneca, Inc.

\*\* MUST be used when using any  
PHMB based sanitizer.

## **MODULE CLEANING PROCEDURE**

**⚠ WARNING** Risk of chemical burns. Do not attempt to acid clean the filter or module. If the filter requires acid cleaning, have a trained pool professional do the job.

Follow all steps in the “Disassembly” section of this manual.

The filter module should be removed and cleaned when pressure rises more than 10 psi (69 kPa) above startup pressure. See also “When to Clean the Filter,” at left.

**NOTICE:** Do not expose the filter module to sunlight for any extended period of time.

**NOTICE:** When sanitizing your pool using PHMB (polyhexamethylene biguanide based) cleaners, use *only* PHMB cleaners to clean the module. When using PHMB sanitizers, the filter module **MUST** be cleaned more thoroughly and frequently than for a pool using chlorine. Follow manufacturer’s instructions carefully. Use of any other type of cleansers with PHMB pool sanitizers will void the filter’s warranty.

**NOTICE:** Avoid washing filter debris into the outlet port. Remove drain plug and flush dirt from inside of tank before removing filter module.

1. With a hose equipped with a soft flow nozzle, wash as much dirt as possible off of the filter module while it is still inside the tank. Allow tank to drain completely.
2. Make sure that the inside of the tank is clean. Lift out the module and hose it down thoroughly. Spray the entire module surface. Allow module to drain.
3. Inspect the module. If necessary, repeat the washing operation. If the module is damaged, replace it.  
**NOTICE:** If this cleaning method does not remove all deposits, see “Special Cleaning Instructions” section in this manual.
4. Inspect and clean air bleed filter at top of module.
5. Follow all steps in the “Assembly” and “Initial Startup” sections of this manual.

## **⚠ WARNING**

**Hazardous pressure.  
Can cause severe  
injury or major  
property damage  
from tank blow up.**

Release all pressure  
and read instructions  
before working on filter.

### **Special Cleaning Instructions:**

Use this procedure to clean scale or oils which are not removed by hosing down module. Be sure to dispose of spent chemicals according to all applicable codes and waste disposal ordinances. Use a soft stream nozzle to minimize flying water and spray.

**⚠ DANGER Risk of fire or explosion. Isolate filter from system before chemical cleaning; rinse filter and elements completely before returning to service.** If filter cannot be isolated, remove media and clean at another location. Follow chemical manufacturer's instructions for use. Do not mix chemicals except as directed by manufacturer. Do not allow cleaning chemicals to mix with or to come in contact with chlorine, bromines, other chemicals, or chemical feed devices.

1. Sponge or spray the module according to chemical manufacturer's directions.
2. If soaking is required, remove the module from the filter tank and submerge it in a separate tank. Follow cleaner manufacturer's instructions carefully.
3. After completing chemical manufacturer's instructions, drain and rinse the module completely. Dispose of cleaners in accordance with local codes and disposal ordinances.
4. Rinse the inside of the filter tank. Drain it completely.
5. Follow instructions in the "Assembly" and "Initial Startup" sections of this manual.

## **SYSTEM INSPECTION**

### **General:**

Wash the outside of the filter with a mild detergent and water. Rinse off with a hose.

**NOTICE:** DO NOT use solvents to clean the filter; solvents may damage plastic components in the system.

**NOTICE:** Open the filter air release valve and release all air from the filter each time the pump is stopped and restarted.

### **Weekly Inspection:**

1. Remove debris from the pool skimmer basket.
2. Stop the pump; open the air release valve to release all pressure.
3. Remove the trap cover and basket; remove debris.
4. Check the pump for leaks. If found, see the pump owner's manual.
5. Replace the trap basket and the cover. Tighten the cover securely hand tight. DO NOT use a lid wrench to tighten it.
6. Start the pump. When the filter air release valve runs a solid stream of water, close the valve.
7. When the system has returned to normal operation, check the filter pressure. If the filter pressure is 10 PSI (69kPa) or more higher than the initial startup pressure, the filter needs cleaning. See "Cleaning the Filter", Page 9.

## WINTERIZING

**▲ WARNING** Explosion hazard. Purging the system with compressed air can cause components to explode, with risk of severe injury or death to anyone nearby. Use only a low pressure (below 5 PSI), high volume blower when air purging the pump, filter, or piping.

### NOTICE

The filter outlet piping will not empty through the filter drain. Make sure that the outlet piping has a separate drain for winterizing.

**NOTICE:** Protect the filter from freezing. Allowing the filter to freeze will damage it and will void the warranty.

1. Clean the filter according to instructions (Page 10) before winterizing. Do not winterize with DE precoat on cartridge or with residual in tank.
2. Stop the pump.
3. Open the air release valve; open all the system valves.
4. Remove the drain plugs from the trap, pump, and filter.
5. Drain the system piping.
  - A. Gravity drain system as far as possible.
  - B. Protect areas which retain water with non-toxic propylene glycol antifreeze ("RV antifreeze").
6. Loosen the union nuts (if used) to drain all water from the filter interior. Leave these nuts loose until the system is restarted.
7. Disassemble the filter (follow instructions under "Filter Disassembly", Page 8). Remove the filter module and store it in a warm, dry area. Be sure to store the cartridge where it will not be in sunlight.
8. Be sure to allow any water trapped in the tank to drain out.
9. Cover the filter with plastic or tarpaulin to prevent water entrance and freezing.

# TROUBLESHOOTING GUIDE

## 1. Short Cycle Time:

**NOTICE:** Cycle Time will vary with each installation and between different areas of the country. The following causes and remedies are for cycle times shorter than normal for your area.

- A. Chlorine residual too low; maintain proper residual (consult pool professional for recommendation).
- B. Flow rate too high; restrict flow to rated capacity of filter (see instruction plate on filter or specifications on Page 6).
- C. Filter is too small; install an additional filter.
- D. Improper/insufficient precoat; see precoat instructions under "Initial Setup" (Page 7).
- E. Filter module is dirty or plugged; thoroughly clean the filter (see No. 4, "Plugged Module Cloth" (below), and "Module Cleaning Procedure", Page 10).
- F. Too much DE; check for clogged filter module.
- G. Water is chemically out of balance; consult pool professional.
- H. Algae in the pool. Apply heavy dose of chlorine or algicide as recommended by the pool manufacturer.

## 2. Low Flow/High Pressure:

- A. Filter Module plugged; clean module thoroughly (see Pages 10 and 11).
- B. Pipe blocked downstream from filter; remove obstruction.
- C. Piping too small; use larger pipe (consult dealer for sizing).
- D. Filter area too small; install an auxiliary filter (consult dealer for recommendation).
- E. Outlet port check valve obstructed (if applicable); remove obstruction to allow valve to open.

## 3. Low Flow/Low Pressure:

- A. Pump too small; consult dealer for recommendations.
- B. Plugged pump or plugged hair and lint trap; clean thoroughly.

## 4. Plugged Module Cloth:

**NOTICE:** The pleated filter material may look matted after use. However, as long as the DE adheres to the pleated cloth, the filter is operating properly.

- A. Insufficient precoat; see precoat instructions (Page 7).

- B. Insufficient cleaning; follow cleaning instructions closely and clean thoroughly (see Pages 10 and 11).
- C. Water is chemically out of balance; consult pool professional.
- D. Excessive air in filter; non-precoated areas may plug. Vent air from tank and check for pump suction pipe leaks. Clean air bleed filter in grid assembly with a hose and soft flow nozzle.
- E. Filter is too small. Install an additional filter.
- F. Pool water contains iron. See "Special Cleaning Instructions", Page 11.
- G. Algae in pool. Apply heavy dose of chlorine or algicide as recommended by the pool manufacturer.
- H. Use of incorrect chemicals with PHMB sanitizers. Replace filter module.
- I. Not enough D.E. precoat. See Table IV, Page 6.

## 5. Pool Water Not Clean:

- A. Chlorine residual too low; maintain adequate chlorine residual (consult pool service technician for recommendation).
- B. Broken filter module passing DE into pool; replace defective module.
- C. Insufficient or improper precoat; follow precoating instructions and use recommended amount of DE (see Pages 6 and 7).
- D. Inadequate turnover rate; consult dealer to verify that equipment is properly sized for your pool.
- E. Pump is too large and is overpumping. Reduce the flow rate.
- F. The filter inlet and outlet are plumbed backwards. Re-plumb them correctly.
- G. Pool water contains iron. See "Special Cleaning Instructions", Page 11.
- H. Heavy or improper application of powdered chlorine tablets using a binder. See "Special Cleaning Instructions", Page 11.
- I. Algae in the pool. Apply heavy dose of chlorine or algicide as recommended by the pool manufacturer.

## 6. Pool Accessories Stop Working:

- A. Clean filter and observe performance of accessories.
- B. If accessories perform better after filter has been cleaned, use a shorter cleaning cycle for the filter (that is, clean the filter after a pressure rise of less than 10 PSI).

**MODELS  
S7MD60  
S7MD72**

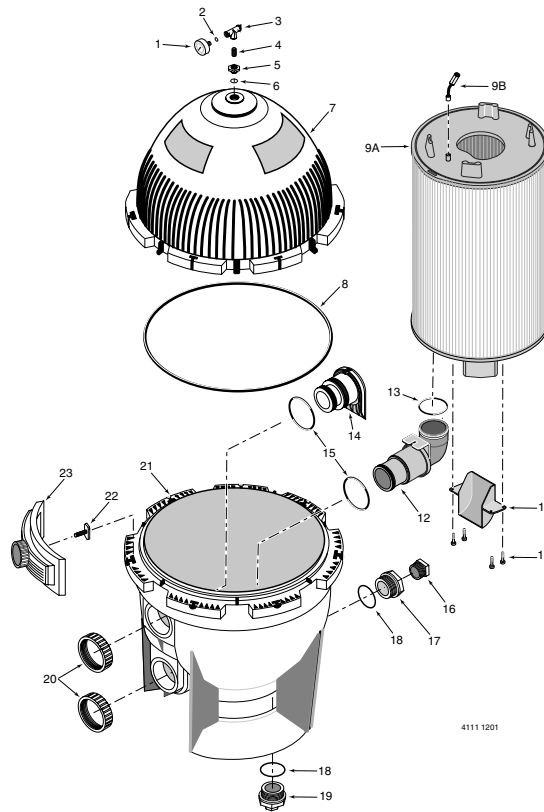

**REPAIR PARTS LIST**

Key No.	Part Description	Model No.	
		S7MD60	S7MD72
1	2 Inch Gauge	33600-0023T	33600-0023T
2	Screen Filter	WC8-72D	WC8-72D
3	Air Release Valve	WC212-120P	WC212-120P
4	Close Nipple 1/4 in.	U37-16P	U37-16P
5	Adapter Bushing	24900-0504	24900-0504
6	O-Ring	35505-1423	35505-1423
7	Upper Tank Shell Kit*	24851-9000	24851-9000
8	Tank O-Ring	24850-0008	24850-0008
9A	Replacement Module	25023-0160S	25023-0172S
9B	Air Bleed Assembly**	24800-0120	24800-0120
10	Baffle Kit (with Screws)**	23910-0013S	23910-0013S
11	Baffle Screws**	37027-7028 (4)	37027-7028 (4)
12	Elbow and Bulkhead Assembly***	23910-0100S	23910-0100S
13	O-Ring	35505-7438	35505-7438
14	Deflector and Bulkhead Assembly	23910-0101	23910-0101
15	O-Ring	35505-1425 (2)	35505-1425 (2)
16	1-1/2" Plug with O-Ring	08419-0201	08419-0201
17	Adapter Fitting	24900-0509	24900-0509
18	O-Ring	35505-1424 (2)	35505-1424 (2)
19	Drain Plug	24900-0503	24900-0503
20	Bulkhead Retaining Nut	24752-0050 (2)	24752-0050 (2)
21	Lower Tank Shell	24850-0102S	24850-0102S
22	Clamp Bolt	24850-0010 (7)	24850-0010 (7)
23	Clamp Assembly	24850-0101 (7)	24850-0101 (7)
•	Warning Decal	32165-4004	32165-4005
•	Decal - Nameplate	32155-4147	32155-4148
•	Decal - Instruction Label	1000001338	1000001338

• Not illustrated

\* Includes all decals and labels.

Quantity one unless otherwise indicated ( ).

\*\* Included with Key No. 9A Replacement Module.

\*\*\* Includes O-Ring (Key No. 13).



## STA-RITE LIMITED WARRANTY

Pumps, filters, skimmers, underwater lights (except bulbs), accessories and fittings manufactured by Sta-Rite are warranted to be free of defects in material and workmanship for one (1) year from date of installation.

<b>Product specific warranties:</b>	<b>Year from date of installation</b>
-------------------------------------	---------------------------------------

<i>HRPB, DEPB, System 3, System 2 and Posi-Clear</i>	
Tanks .....	10 years
Internal filter components and valves .....	1 year
<i>Max-E-Therm - Pool/Spa Heaters</i> .....	
Heater Enclosure only (Upper RH & LH; lower enclosure; and control board enclosure)...	10 years
<i>Automatic Pool Cleaners including Hose</i> .....	
	2 years
<i>Cristal-Flo filters - Tanks</i> .....	
Valve and internal components. ....	1 year
<i>Posi-Flo II - Tanks</i> .....	
Elements .....	1 year
<i>PRC Cartridge -</i>	
Filter Tanks .....	5 years pro-rated (1st 2 years full)
Elements .....	1 year
<i>System 2 Above Ground Systems - Tanks</i> .....	
Pumps / Platform and Internals .....	1 year
<i>Pumps</i> .....	
When equipped with A.O. Smith 2-compartment motors (Does not include pumps sold as part of a systems package) .....	2 years
<i>Traps / In-Line Strainers</i> .....	
	1 year
<i>Vertical Commercial Filter - Tanks</i> .....	
Internals .....	1 year
<i>Horizontal Commercial Filter</i>	
Tanks .....	5 years
(Years 6-9, Prorated declining 20%/year, Yr. 10 - 10%)	
Internals .....	1 year

\* Full warranty coverage is in effect for one year after installation. The pro-rated warranty covers the *tank only* during the 2nd through 10th year after installation. The amount covered decreases by 10% each year. (ie., 2nd year 90% covered, 3rd year 80% covered, etc.).

The foregoing warranties relate to the original consumer purchaser ("Purchaser") only. Sta-Rite shall have the option to repair or replace the defective product, at its sole discretion. Purchasers must pay all labor and shipping charges necessary to replace the product covered by this warranty. Requests for warranty service must be made through the installing dealer. This warranty shall not apply to any product that has been subject to negligence, misapplication, improper installation or maintenance, or other circumstances which are not in Sta-Rite's direct control.

This warranty sets forth Sta-Rite's sole obligation and Purchaser's exclusive remedy for defective products.

STA-RITE SHALL NOT BE LIABLE FOR ANY CONSEQUENTIAL, INCIDENTAL OR CONTINGENT DAMAGES WHATSOEVER.

THE FOREGOING WARRANTIES ARE EXCLUSIVE AND IN LIEU OF ALL OTHER EXPRESS WARRANTIES. IMPLIED WARRANTIES, INCLUDING BUT NOT LIMITED TO THE IMPLIED WARRANTIES OF MERCHANTABILITY AND FITNESS FOR A PARTICULAR PURPOSE, SHALL NOT EXTEND BEYOND THE DURATION OF THE APPLICABLE EXPRESS WARRANTIES PROVIDED HEREIN.

Some states do not allow the exclusion or limitation of incidental or consequential damages or limitations on how long an implied warranty lasts, so the above limitations or exclusion may not apply to you. This warranty gives you specific legal rights and you may also have other rights which vary from state to state.

Supersedes all previous publications.

**Sta-Rite Industries**  
293 Wright St., Delavan, WI 53115

▲ Retain Warranty Certificate (upper portion) in a safe and convenient location for your records.

DETACH HERE: Fill out bottom portion completely and mail within 10 days of purchase/installation to:

▼ Sta-Rite, Attn: Warranty Dept., 293 Wright St., Delavan, WI 53115

**STA-RITE®**



## Warranty Registration Card

Name \_\_\_\_\_

Years pool has been in service  less than 1  1-3  3-5  5-10 \_\_\_\_\_

Address \_\_\_\_\_

Purchased from:  
Company name \_\_\_\_\_

City \_\_\_\_\_ State \_\_\_\_\_ Zip \_\_\_\_\_

Address \_\_\_\_\_

Purchase Date \_\_\_\_\_

City \_\_\_\_\_ State \_\_\_\_\_ Zip \_\_\_\_\_

Product Purchased \_\_\_\_\_

New installation  Replacement \_\_\_\_\_

Please send me more information on these other products from Sta-Rite.

Type of Pool  Inground  Vinyl  Fiberglass  Gunite \_\_\_\_\_

- Pumps  Filters  Automatic Pool Cleaners
- Maintenance Equipment  Test Strips
- Heaters

Size of Pool \_\_\_\_\_