

SWIMMING POOL PUMP FOR POOLS AND SPAS

OWNER'S MANUAL

PUMP MOTOR MANUAL

REMOTE INTERFACE GUIDE



MODEL# APEXVS165, ITEM# 59927-XXXX

877.278.2797 fax 888.610.3839

323165-018 6/18 V1

Please read and save these instructions. Read carefully before attempting to assemble, install, operate or maintain the product described. Protect yourself and others by observing all safety information. Failure to comply with instructions could result in personal injury and/or property damage! Retain instructions for future reference.

IMPORTANT SAFETY INSTRUCTIONS READ AND FOLLOW ALL INSTRUCTIONS

⚠ WARNING To reduce the risk of injury, do not permit children to use this product unless they are closely supervised at all times.

⚠ WARNING Risk of Electric shock. Connect only to a branch circuit protected by a ground-fault circuit-interrupter (GFCI). Contact a qualified electrician if you cannot verify that the receptacle is protected by a GFCI.

The unit must be connected only to a supply circuit that is protected by a ground-fault circuit-interrupter (GFCI). Such a GFCI should be provided by the installer and should be tested on a routine basis. To test the GFCI, push the test button. The GFCI should interrupt power. Push the reset button. Power should be restored. If the GFCI fails to operate in this manner, the GFCI is defective. If the GFCI interrupts power to the pump without the test button being pushed, a ground current is flowing, indicating the possibility of an electric shock. Do not use this pump. Disconnect the pump and have the problem corrected by a qualified service representative before using.

⚠ CAUTION This pump is for use with permanently-installed pools and may also be used with hot tubs and spas if so marked. Do not use with storable pools. A permanently-installed pool is constructed in or on the ground or in a building such that it cannot be readily disassembled for storage. A storable pool is constructed so that it is capable of being readily disassembled for storage and reassembled to its original integrity. Do not install within an outer enclosure or beneath the skirt of a hot tub or spa.

SAVE THESE INSTRUCTIONS. Contents

Description 2
 Safety guidelines 2
 General safety information 2 - 3

Pool safety guidelines 3
 Responsible adult supervision 3
 Drains, suction fittings, and jets . . . 3
 Electrical hazards 3
 Drowning prevention 3
 Indoor installations 3
 Warning signs 3
 Installation 3 - 5
 Threaded connections 3
 Pump plumbing 3 - 4
 Plumber's seal taping instructions . . 4
 Fittings 4
 Prior to pressure testing 4
 Swimming pool pump
 suction requirements 4
 Outlets per pump 4
 Electrical 4 - 5
 Voltage 4 - 5
 Grounding/bonding 5
 Wiring 5
 Operation 5
 Priming pump 5
 Maintenance 5 - 7
 Draining pump 5
 Storage/winterizing 5
 Pump service 6 - 7
 Repair 7
 Troubleshooting guide 7
 Swimming pool pump
 flow rates 7 - 8
 Notes 8 - 9
 Parts diagram 10
 Replacement parts list 11
 Warranty 12

Description

The self priming pool pump is designed for high efficiency, and easy maintenance, with an oversized strainer basket. It is constructed of durable thermoplastic for years of trouble free service. This swimming pool pump is designed for use with permanently installed swimming pools and spas only. Do not use with storable pools.

Unpacking

After unpacking the unit, carefully inspect for any damage that may have occurred during transit. Check for loose, missing or damaged parts.

Safety Guidelines

This manual contains information that is very important to know and understand. This information is provided for SAFETY and to PREVENT EQUIPMENT PROBLEMS. To help recognize this information, observe the following symbols.

Danger indicates an



Figure 1 - Swimming Pool Pump

⚠ DANGER imminently hazardous situation which, if not avoided, will result in death or serious injury.

⚠ WARNING Warning indicates a potentially hazardous situation which, if not avoided, could result in death or serious injury.

⚠ CAUTION Caution indicates a potentially hazardous situation which, if not avoided, may result in minor or moderate injury.

NOTICE Notice indicates important information, that if not followed, may cause damage to equipment.

NOTE: Information that requires special attention.

General Safety Information

As a user, you are important to us. Thus, one copy of the Operating Instructions and Parts Manual is included with each pump shipped from our factory. This manual contains important sections relative to user safety, use, maintenance, warranty, etc. It is a good idea to ask for extra copies for other installers/users. Extra copies, free of charge, are available.

CALIFORNIA PROPOSITION 65

⚠ WARNING This product may contain chemicals known to the State of California to cause cancer and birth defects or other reproductive harm. Wash hands after handling.

GENERAL SAFETY

Do not use pump for any purpose other than pool/spa application. Components have not been designed for other applications. Severe pump failure, may result. Any unapproved use will void warranty.

REMINDER: Keep your dated proof of purchase for warranty purposes! Attach it to this manual or file it for safekeeping.

General Safety Information (Cont.)

Always follow basic safety precautions with this equipment, including:

- Provide sufficient ventilation to maintain air temperature below the maximum ambient temperature rating shown on the motor nameplate. Pump house must allow adequate ventilation to assure the ambient temperature remains below the motor rating when the pump is operating.
- Locate pump on a non combustible surface. The surface should be hard, level, dry, well ventilated, out of direct sunlight. The surrounding area should provide protection from the elements and allow sufficient space for maintenance and service. Ensure the drainage will flow away from the pump. To reduce vibration and pipe stress, use anchor bolts to secure pump base to surface. Support the suction and discharge piping.
- Design the piping system to allow the pump suction inlet height to be as close to water level as possible. Mount pump below water level for easy priming. If the pump must be located above the filled water level, keep the vertical distance to a minimum. Use short, direct piping to the suction this will minimize friction loss.

- ▲ WARNING** *Fire and burn hazard. Motors run at high temperatures. Do not allow leaves, debris, or foreign matter to collect around the pump motor. Keep ventilation holes open. Allow motor to cool before handling. Keep flammable liquids away.*
- If the thermal overload protection

in the motor trips or if the GFCI trips determine the reason and correct the problem before re-starting pump.

- Use rigid or flexible PVC pipe. Ensure pipe ends are clean and free of any flash caused by cutting. Use the proper glue for the type of pipe selected.

NOTE: Use a supplier recommended primer to ensure glued joints are secure. Many local codes require primer with a purple tracer to verify primer use.

- Consider climatic conditions when applying adhesives. Atmospheric conditions with high humidity will make the adhesive action of certain glues less effective. Follow the manufacturer's instructions.

Pool Safety Guidelines

RESPONSIBLE ADULT SUPERVISION

Constant and responsible adult supervision is mandatory in the pool or spa environment. Always supervise children around pools and spas. Never allow a child to play in a way that could permit the child's hair to come near the drain cover.

DRAINS, SUCTION FITTINGS, AND JETS

Keep hair and clothing away from the suction fitting drain cover. Wear a bathing cap or pin hair up if you have long hair. Current grates and covers help prevent body or hair entrapment. Make sure that drain covers meet the ANSI/ASME A112.19.8 standard. Safety doors should be installed in all pool cleaner wall suction lines. Pools or spas with drain covers that are broken, missing, or not adequately secured should not be used until the proper replacement has been installed.

ELECTRICAL HAZARDS

A licensed electrician, experienced in swimming pools and spas, should inspect your equipment to make sure everything is properly grounded, bonded, and protected by proper GFCI circuits according to Article 680 of the National Electric Code.

DROWNING PREVENTION

Install and routinely inspect fences, self-closing and latching gates, baby barrier fences, and alarms. Eliminate incidental routes to pool including machinery or equipment that provides a route over fencing into pool area.

INDOOR INSTALLATIONS

Pools and spas located indoors must comply with ANSI/ASHRAE (American Society of Heating, Refrigeration and Air-Conditioning Engineers) standard 62-2001 to ensure adequate ventilation and safe use.

WARNING SIGNS

Protect your family and guests. Make sure that all warning signs provided by the manufacturer, builder, or installer are displayed according to the manufacturer's specifications.

Installation

▲ DANGER *Shock Hazard! Only qualified, licensed personnel should install pump and wiring.*

▲ WARNING *A professional trained and familiar with pool pump installation must perform pressure tests.*

The pump mount must be located away from corrosive or flammable chemicals. Do not connect the pump to a municipal

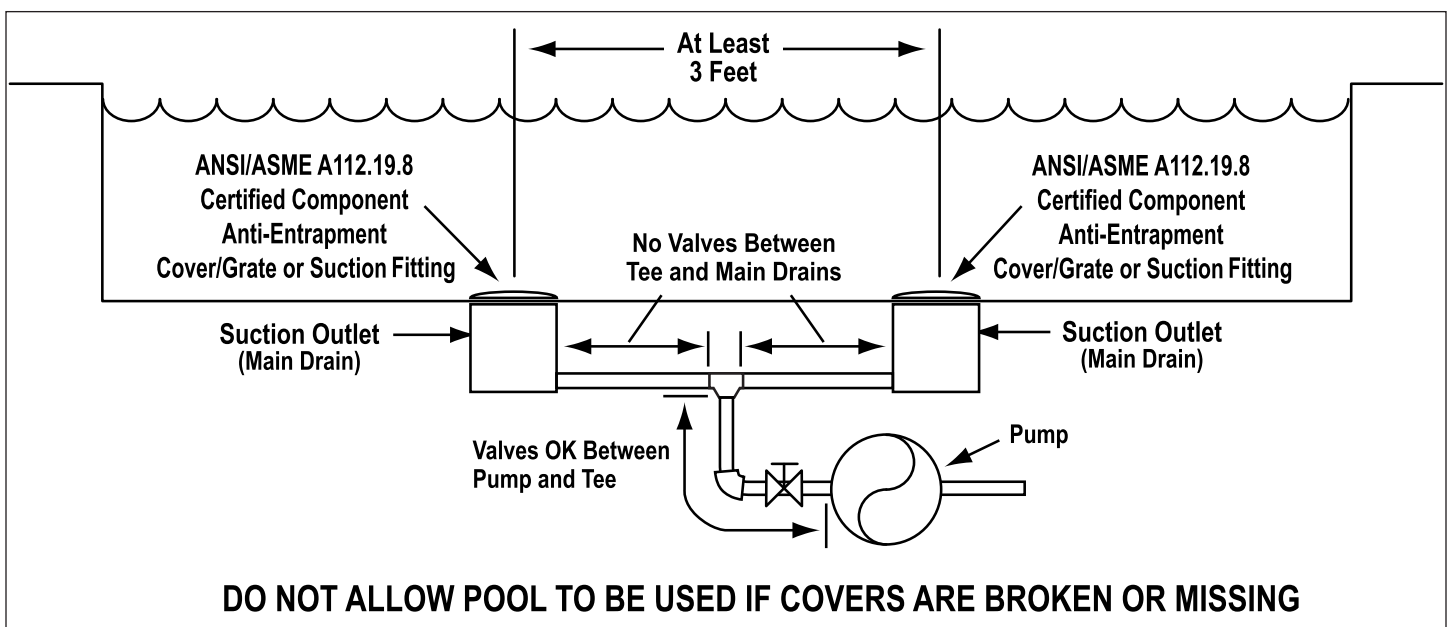

Figure 2

Installation (Cont.)

water system. The pump is only designed for pool or spa installation. The pump must be installed with at a minimum of 2 main drains equipped with certified anti-entrapment covers that comply with ASME/ANSI A112.19.8B standard (see Figure 2). All air must be removed from piping system before operating or testing equipment (see filter manual).

THREADED CONNECTIONS

Use only Plumber's Seal tape or equivalent on threaded plumbing connections. Other pipe compounds may damage threads. Do not use silicone or petroleum based compounds.

PUMP PLUMBING

Suction pipe should be as large as or larger than discharge pipe. Avoid using a suction pipe smaller than pump connection. The pump is designed to accept either 2 or 3 inch suction piping. Larger diameter pipes reduce noise and improve performance.

1. Keep the piping as straight and short as possible, and of suitable size.
2. Avoid connecting an elbow directly into the pump inlet. A length of straight pipe will allow proper entry of the water to the pump.
3. Slope horizontal runs upward to the pump to prevent trapping air.
4. Use independent piping supports to reduce strain on the pump.
5. Keep as much of the suction line as possible below the water level to reduce priming time.
6. Install valves and unions in the pump suction and return lines to facilitate servicing. Valves are also essential for pump maintenance if the system is installed below pool water level.
7. Keep all valves fully open during operation. Partially closed valves waste energy!

Use Plumber's Seal tape for making threaded connections to the pump. Do not use pipe dope.

PLUMBER'S SEAL TAPING INSTRUCTIONS

Use only new or clean PVC pipe fittings. Wrap male pipe threads with one to two layers of Plumber's Seal tape. Cover entire threaded portion. Do not over tighten. If leaks occur, remove pipe, clean off old tape, rewrap with one to two additional layers of tape and remake the connection.

NOTICE

Internal - 2 in. NPT are available for direct

connection to pipe. The suction line is also designed to accept 3 in. NPT external threaded connection. For best results use the larger diameter suction line.

FITTINGS

Fittings restrict flow; for best efficiency use fewest possible fittings. Avoid fittings which could cause an air trap. Pool fittings must conform to International Association of Plumbing and Mechanical Officials (IAPMO) standards. Use only non-entrapping suction fitting or double suction.

PRIOR TO PRESSURE TESTING

- Securely tighten knobs, drain fittings, lid, and system accessories
- Air may collect at the highest point in the plumbing system. Normally an air purge valve is provided with the pool filter. Consult pool filter instruction manual for air purging instructions.
- Basket lid must be rotated and locked into position as indicated in Figure 3.
- Test system at a water pressure of 25 psi or less

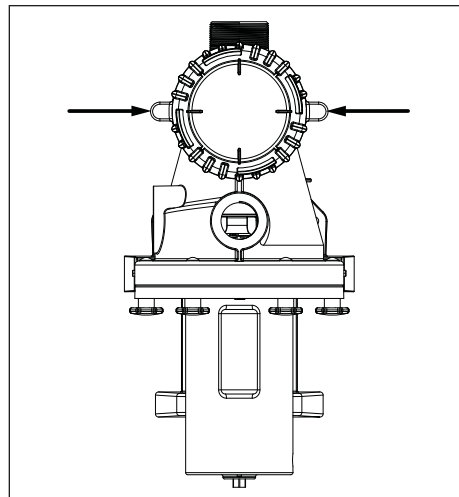

Figure 3 - Clamp rings

- Water Temperature for test must be less than 100° F
- After 24 hours visually check system for leaks.

POOL PUMP SUCTION REQUIREMENTS

⚠ DANGER *Pump suction is hazardous and can trap, drown or disembowel bathers. Do not use or operate swimming pools or spas if a suction outlet cover is missing, broken, or loose. Follow the guidelines below for a pump installation which minimizes risk to users of pools and spas.*

⚠ DANGER *Ground the motor before connecting to electrical power supply. Failure to ground the motor may cause severe or fatal electrical shock hazard.*

ENTRAPMENT PROTECTION

The pump suction must be designed to eliminate the possibility of suction entrapment or hair entrapment/entanglement.

SUCTION COVERS

All suction inlet covers must be maintained and replaced if cracked, broken, or missing. See Figure 2 for outlet cover certification requirements.

TESTING AND CERTIFICATION

All suction inlet covers must comply with ASME/ANSI A112.19.8B specifications for suction fittings for use in swimming pools, spas and whirlpool bathtub applications. The product must be tested for compliance with the standards and the certification must be included with the components.

Single or Multiple Pump Circulation Systems must be provided with a minimum of 2 (two) suction inlets of the approved type.

Do not install multiple pumps in one hydraulic circuit. The pump is not designed to accept output flow from another pump. Do not allow water to back flow through the pump. Water flowing in the discharge and out the suction during an upset condition can cause the motor to rotate backwards. Never attempt to start pump if shaft is rotating due to a hydraulic turbine action, this could cause pump to operate in reverse and damage internal components.

⚠ DANGER *Any pool or spa should immediately be closed if the cover or grate is damaged or missing.*

OUTLETS PER PUMP

Provide at least two hydraulically balanced main drains, with covers for each swimming pool pump suction line. The centers of the main drains suction fitting must be at least three feet apart (see Figure 2). The system must be built so that it cannot operate with the pump drawing water from only one main drain. Two main drains must be connected to the pump whenever it is running. If two main drains run into a single suction line, the single suction line can be equipped with a single valve that shuts off both main drains from the pump. **A valve in each suction line is not allowed.**

Electrical

A Ground Fault Circuit Interrupter (GFCI) is required in the circuit. For size of GFCI required see manufacturer's instructions.

- Never ground to a gas supply line.
- To avoid dangerous or fatal electrical shock: turn OFF, disconnect the power at its source, lock out power to motor, and place a tag on the dedicated GFCI circuit breaker indicating the power is to remain OFF before working on electrical connections.

Ground Fault Circuit Interrupter (GFCI) tripping indicates an electrical problem. If GFCI trips, determine the reason for tripping. If you are uncertain, have a qualified electrician inspect and repair the electrical system. Verify supply voltage matches the nameplate voltage. Incorrect voltage can cause fire or seriously damage motor and voids warranty.

VOLTAGE

Voltage at motor must be within 10% of the motor nameplate rated voltage or motor may overheat, causing overload tripping and reduced component life. Verify voltage is correct before applying power. If voltage does not fall within the specified range during operation consult the power company.

The pumps are shipped with motors wired for 208-230 volt operation. The 3/4, 1 and 1-1/2 HP models are equipped with a voltage change device for 115/208-230 operation. Refer to the motor nameplate for 115 Volt hook-up.

GROUNDING/BONDING

Install, ground, bond and wire motor according to local or National Electrical Code requirements. Permanently ground the motor. Use ground terminal provided in the terminal box on the back of the motor. Use size and type wire required by local codes. Connect motor ground terminal to electrical service ground.

Bond motor to pool structure. Use a solid copper conductor, size No. 6 AWG or larger. Run wire from external bonding lug to reinforcing rod or mesh.

Use solid copper bonding conductor not smaller than 6 AWG (13 mm²) from the accessible wire connector on the motor to all metal parts of the swimming pool or spa structure and to all electrical equipment, metal conduit, and metal piping within 5 feet (1-1/2 m) of the inside walls of the swimming pool or spa.

WIRING

Follow all national and local wiring codes. If unsure of code requirements consult a professional electrician. Pump must be permanently connected to a dedicated circuit. If unsure consult a licensed electrician.

NOTE: All electrical wiring and components must be selected and installed in conformance with the latest NEC requirements and local codes. If you are unsure about the requirements consult a licensed electrician familiar with the requirements.

Operation

Do not run pump dry. Fill pump with water before starting motor.

Before removing trap cover:

1. CLOSE GATE VALVES in suction and discharge pipes
2. RELEASE ALL PRESSURE from pump and piping system

If pump is being pressure tested, be sure pressure has been released before removing trap cover.

Do not block pump suction. To do so with body may cause severe or fatal injury. Small children using pool must ALWAYS have close adult supervision.

▲ WARNING *Fire and burn hazard. Motor runs at high temperatures, to reduce the risk of fire, do not allow debris, or foreign matter to collect around the pump motor. Allow motor to cool prior to handling or performing maintenance.*

The motor is equipped with an internal thermal protection circuit to guard against overheating. The maximum ambient temperature for motor operation must not exceed rating on motor model plate.

PRIMING PUMP

Release all pressure from filter, pump, and piping system; see the filter owner's manual. In a flooded suction system (water source higher than pump), pump will prime automatically when suction and discharge valves are opened. If pump is located above the normal pool water level remove ring and cover assembly and slowly fill basket and pump with water. Clean and inspect o-ring; reinstall on trap. Replace ring and cover assembly rotate clockwise to tighten cover (see Figure 3).

Clamp ring must engage with pump body. Push down and rotate until internal stops are felt. Properly aligned tabs shown above in Figure 3, assure lid is securely clamped.

Failure to tighten clamp ring as indicated will reduce product strength, resulting in failure of components, and bodily injury.

NOTICE

Pump prime time will depend on vertical distance and length of suction line. If pump does not prime, make sure that all valves are open, suction pipe is submerged. Verify there are no leaks in suction lines. See Troubleshooting Guide for further assistance.

Maintenance

All of our pumps are shipped from the factory with DANGER and/or WARNING labels already on the pump. These labels contain a series of basic, yet extremely important safety messages for the user and bystander. Regardless of how well these labels are attached or how scratch resistant or wear-resistant they may be, it is possible that, in time, the wording may become illegible with normal use. Whenever you are repairing the pump, performing routine maintenance, or have the opportunity to inspect the pump, make sure the label is readable. If the label is not legible, replace the label with an adhesive version that is available at no charge by calling 1-877-278-2797. The unit must be connected only to a supply circuit that is protected by a ground-fault circuit-interrupter(GFCI). Such a GFCI should be provided by the installer and should be tested on a routine basis. To test the GFCI, push the test button. The GFCI should interrupt power. Push the reset button. Power should be restored. If the GFCI fails to operate in this manner, the GFCI is defective. If the GFCI interrupts power to the pump without the test button being pushed, a ground current is flowing, indicating the possibility of an electric shock. Do not use this pump. Disconnect the pump and have the problem corrected by a qualified service representative before using.

Use only parts supplied by manufacturer. Similar looking parts may not have sufficient strength for safe operation.

The only routine maintenance needed is inspection/cleaning of strainer basket. Debris or trash that collects in basket will choke off water flow through the pump.

Before attempting to clean basket:

- A. Stop pump, disconnect power at its source, lock out power, place tag on the dedicated GFCI circuit breaker indicating the power is to remain OFF, close valves in suction and discharge, and release pressure from system.

Maintenance (Cont.)

⚠ DANGER *Hazardous suction can trap hair or body parts, causing severe injury or death. Do not block suction.*

- B. Remove ring and cover assembly by turning counterclockwise. If necessary, tap handles gently with a rubber mallet.
- C. Remove basket and clean. Inspect holes in basket for blockage. Clean basket with water and replace in basket housing. Do not hit basket to clean. Verify basket is oriented correctly in housing.
- D. Clean and inspect lid o-ring; reinstall ring and cover assembly.
- E. Prime pump (see priming instructions).

DRAINING PUMP

⚠ DANGER *To avoid dangerous or fatal electrical shock hazard, turn OFF power to motor before draining pump. Disconnect power at its source, lock out the power, and place a tag on the dedicated GFCI circuit breaker indicating the power is to remain off.*

- A. Close suction discharge valves to isolate pump.
- B. Drain the basket housing and pump housing through the drain plugs.
- C. Be sure motor is kept dry and covered.

STORAGE/WINTERIZING

⚠ DANGER *Explosion hazard. Purging the system with compressed air can cause components to explode, with risk of severe injury or death to anyone nearby. Use only a low pressure (below 5 psi), high volume blower for purging the pump, filter, or piping.*

NOTICE *Allowing pump to freeze will damage pump and void warranty!*

NOTICE *Use only non-toxic anti-freeze. Do not use automotive antifreeze. It is highly toxic and may damage plastic components in the system.*

PUMP SERVICE

If the pump mechanical seal (reference numbers 8a and 8b on page 9) starts leaking replace it immediately to avoid damage to motor or other components. Pump should only be serviced by qualified personnel. Use only our factory parts.

BEFORE REMOVING CLAMP ON BASKET HOUSING:

- STOP PUMP ELECTRICALLY: Disconnect the power at its source, lock out the power, and place a tag on the dedicated GFCI circuit breaker

- indicating the power is to remain OFF.
- CLOSE GATE VALVES in suction and discharge pipes.
- RELEASE ALL PRESSURE from pump and piping system. Refer to the filter manual for method.
- NEVER tighten or loosen clamp while pump is operating!

⚠ DANGER *To avoid dangerous or fatal electrical shock hazard, turn OFF and lock out power to motor before working on pump or motor.*

REPAIR

DISASSEMBLY

1. Disconnect power at its source, lock out the power, and place a tag on the dedicated GFCI circuit breaker indicating the power is to remain OFF.
2. Drain pump by removing drain plugs on bottom of pump body and basket body.
3. Disconnect electrical connections at motor.
4. Remove six knobs holding seal plate to pump body.
5. Slide motor/seal plate assembly out of the back of the pump.
6. Remove three screws holding diffuser to seal plate.
7. Remove motor shaft cover on rear of motor on all models except 59923-XXXX as you can fit a screw driver in the hole without removing back cover. (see Figure 4). Use a wrench or a large screw driver to stop motor shaft rotation.



Figure 4

8. Remove screw from center of impeller. The threads are reversed. Turn clockwise to loosen screw (Figure 5).

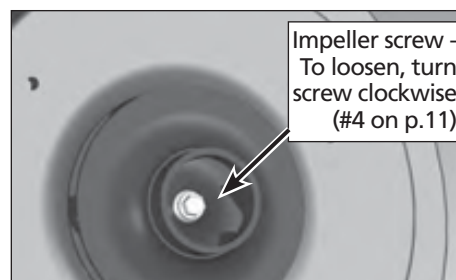

Figure 5

9. Then grasp impeller and rotate counterclockwise to remove impeller from shaft.
10. Pull mechanical seal rotating assembly from motor shaft.

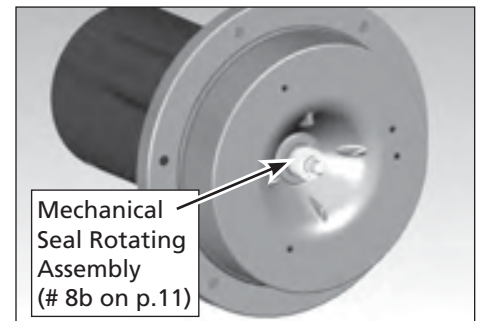

Figure 6

11. With a screw driver carefully pry old stationary seat from seal plate (see Figure 7). DO NOT SCRATCH SEAL BORE.

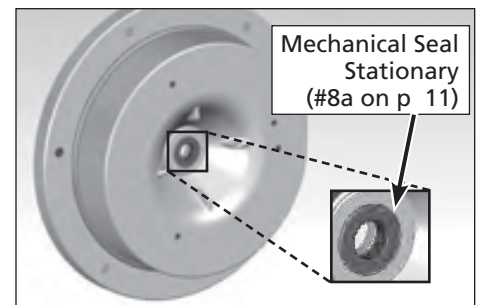

Figure 7

12. If shaft is corroded or dirty motor will need to be removed from seal plate so that the shaft can be effectively cleaned.
13. If necessary use a 9/16 socket with a 6 inch extension to remove four screws holding motor to seal plate. If seal has been leaking for a long time the motor bearing may be compromised, if excessive corrosion or shaft end play can be detected motor will need to be replaced.

REASSEMBLY

1. Obtain a new mechanical seal rotating assembly and seat (reference numbers 8a and 8b on page 11). Seal parts must be replaced as a set. Do not mix old and new parts. Lubricate seal stationary o-ring with a very small amount of dish soap. Do not allow soap, dirt, grease, or any contaminate on the polished seal face (see Figure 8). Install seal with 2 dimples toward motor or seal will fail.

Maintenance (Cont.)

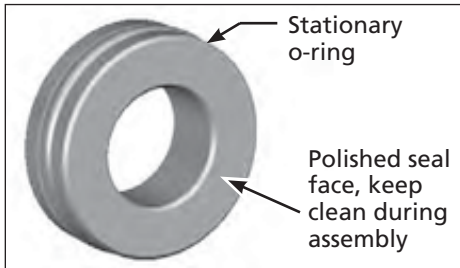

Figure 8

Clean bore for seal, then press seal stationary into bore. Cover seal face with cardboard or other suitable material to avoid touching polished seal face. Verify seal is fully seated in the bottom of the bore.

2. Reinstall motor if removed, lubricate clean motor shaft with a small amount of dish soap. Slide the new rotating seal assembly on to the motor shaft until it is even with the shaft shoulder. Polished carbon face must mate with polished stationary face. Make certain seal is properly seated in housing.
3. Screw impeller on to motor shaft. Install left handed retaining screw and washer.
4. Install floating wear ring on impeller. Be careful to install with flange pointing out (see Figure 9).

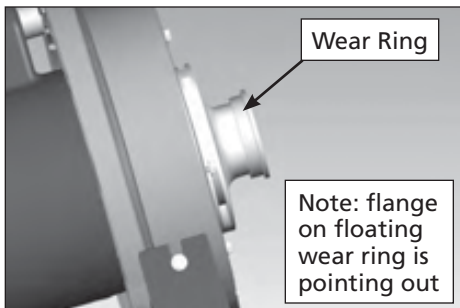

Figure 9

5. Replace diffuser o-ring (reference part #5 on page 11) if it is damaged. Clean o-ring groove before installing a new o-ring.
6. Install diffuser with 3 screws, coat o-ring with a small amount of dish soap to make assembly into pump body easier.

7. Replace main seal plate o-ring with a new one. Clean the surface before installing.
8. Slide rotating assembly back into pump housing.
9. Tighten six knobs in a staggered pattern so all screws are tightened evenly.
10. Pump is now ready to return to service.

⚠ DANGER Voltage can shock, burn, or cause death. Disconnect power before working on pump or motor. Disconnect power at its source, lock out the power, and place a tag on the dedicated GFCI circuit breaker indicating the power is to remain off.

Troubleshooting Guide

Read and understand safety and operating instructions in this manual before doing any work on pump! Only qualified personnel should electrically test pump motor!

WATER LEAKING AROUND MOTOR:

A water leak in the area of the motor to pump connection indicates a mechanical seal failure and a shock hazard. Take pump out of service and replace seal immediately to avoid damage to other components and to reduce risk of electric shock. Refer to pump maintenance section.

FAILURE TO PUMP: REDUCED CAPACITY OR DISCHARGE PRESSURE

SUCTION LEAKS/LOST PRIME:

1. Pump must be primed; make sure that pump body and basket body are full of water. See priming instructions.
2. Make sure there are no leaks in suction piping.
3. Make sure suction inlet is well below the water level to prevent pump from sucking air.
4. Lower pump closer (vertically) to water source or install check valve in suction line.

⚠ WARNING Some safety vacuum release system (SVRS) devices are not compatible with installation of check valves. If the pool has an SVRS device, be sure to confirm that it will continue to safely operate when any check valves are installed.

CLOGGED PIPE/TRAP/IMPELLER, WORN IMPELLER:

5. Make sure suction trap is not clogged; if it is, clean trap and strainer. See Maintenance section.
6. Make sure impeller is not clogged (follow steps 1 through 7 under "DISASSEMBLY", Page 6; check impeller for clogging; follow steps 7 through 10 under "REASSEMBLY", Pages 6 - 7, for reassembly).
7. Impeller and diffuser may be worn. If so, order replacement parts from "Repair Parts List", on pages 10 and 11.
8. Pump may be trying to push too high a column of water. If so, a "higher head" pump is needed. Call 1-877-278-2797.

ELECTRICAL:

9. Pump may be running too slowly; check voltage at motor terminals and at meter while pump is running. If low, see wiring instructions or consult power company. Check for loose connections.
10. Pump may be too hot.
 - A. Check line voltage; if less than 90% or more than 110% of rated voltage consult a licensed electrician.
 - B. Increase ventilation.
 - C. Reduce ambient temperature.
 - D. Tighten any loose connections.

MECHANICAL TROUBLES AND NOISE

1. If suction and discharge piping are not adequately supported, pump assembly will be strained. See "Installation", Page 3 - 4.
2. Do not mount pump on a wooden platform! Securely mount on concrete platform for quietest performance. Use anchor holes provided in pump base.

Swimming Pool Pump Flow Rates

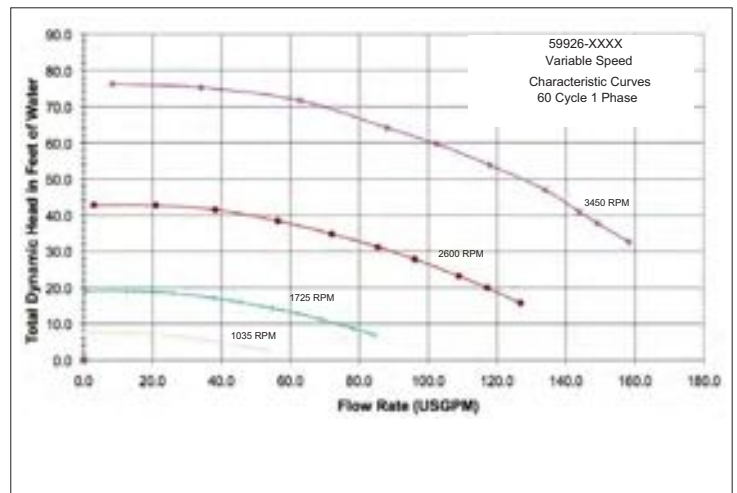
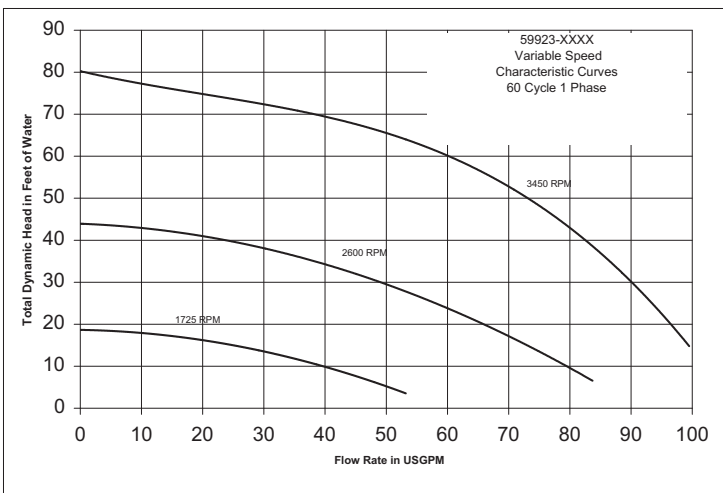
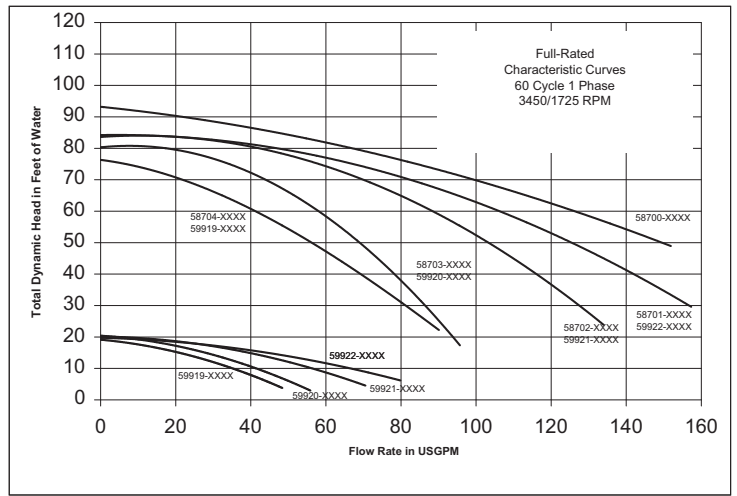
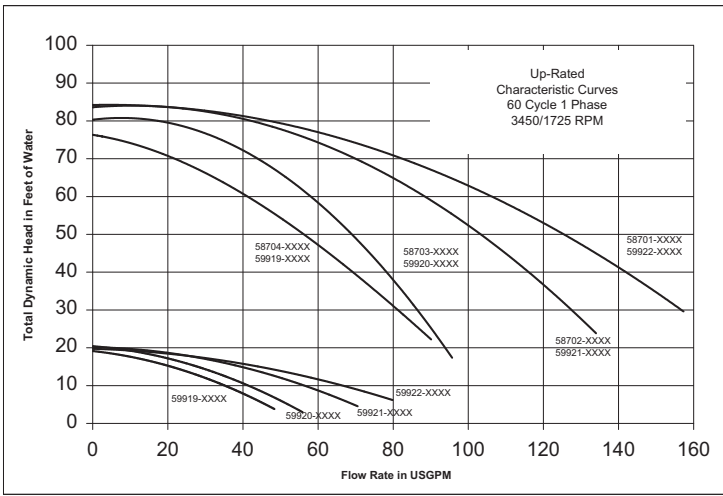

For replacement parts or technical assistance, call 1-877-278-2797

Please provide following information:

- Model number
- Serial number
- Part description and number as shown in parts list

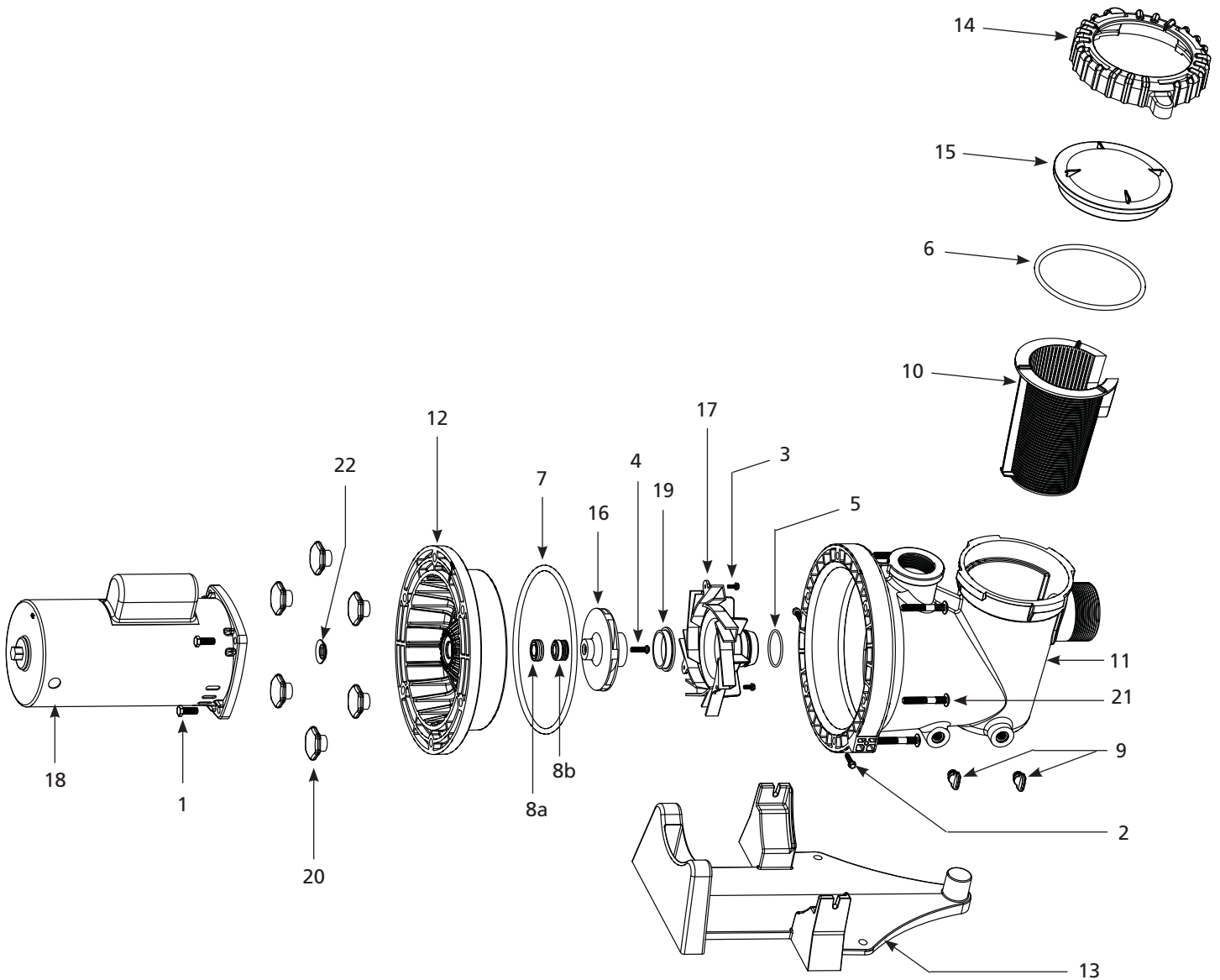

Replacement Parts List

Ref. No.	Description	Part Number	Qty.
1	Machine Screw 3/8-16 x 1.00 UNC 2A	4383	4
2	Base Screw	4951	2
3	Machine Screw 10-32 x 1/2 UNC 2A	08831	3
4	Machine Screw 1/4-20 x 1 UNC 2A Left Handed	14052	1
5	Diffuser O-Ring	19014-001	1
6	Strainer Basket O-Ring	19084-001	1
7	Housing O-Ring	19087-002	1
8a	Seal Stationary	21212-001	1
8b	Bellows Assembly	21212-002	1
9	Drain Plug	14421	2
10	Filter Basket	28570-001	1
11	Pump Housing	28571-002	1
12	Seal Plate	28572-001	1
13	Pool Pump Base	28573-001	1
14	Locking Ring	29595-001	1
15	Clear Basket Cover	29596-001	1
16a	3/4 HP Impeller (58704-XXXX, 59919-XXXX, 59923-XXXX)	29860-001	1
16b	1 HP Impeller (58703-XXXX, 59920-XXXX)	29859-001	1
16c	1-1/2 HP Impeller (58702-XXXX, 59921-XXXX)	29861-001	1
16d	2 HP Impeller (58701-XXXX, 59922-XXXX)	29862-001	1
16e	3 HP Impeller (58700-XXXX)	29858-001	1
17a	Diffuser 5 Vane (58704-XXXX, 59919-XXXX, 59923-XXXX)	29864-001	1
17b	Diffuser 7 Vane (58703-XXXX, 58702-XXXX, 58701-XXXX, 59920-XXXX, 59921-XXXX, & 59922-XXXX)	29863-001	1
17c	Diffuser 3 HP (58700-XXXX)	29863-002	1
18a	3/4 HP Motor (58704-XXXX)	32166-001	1
18b	1 HP Motor (58703-XXXX)	32165-001	1
18c	1-1/2 HP Motor (58702-XXXX)	32164-001	1
18d	2 HP Motor (58701-XXXX)	32163-001	1
18e	3 HP Motor (58700-XXXX)	32162-001	1
18F	1 HP Variable Speed Motor	32198-001 (59923-XXXX)	1
18G	2 HP 2 Speed Motor	32197-001 (59922-XXXX)	1
18H	1.5 HP 2 Speed Motor	32196-001 (59921-XXXX)	1
18I	1 HP 2 Speed Motor	32195-001 (59920-XXXX)	1
18J	3/4HP 2 Speed Motor	32194-001 (59919-XXXX)	1
18K	2.4 HP Variable Speed Motor	32200-001	1
18L	3.4 HP Variable Speed Motor	32201-001	1
19	Floating Wear Ring	46066-001	1
20	Knob	67121-001	6
21	Rib Neck Bolts	67122-001	6
22	Slinger	(Included with Motor, parts 18a-j)	1
REPLACEMENT PART KITS			
	Seal Kit	69013-001	(Parts 6 & 7)
	Motor Kit		
	3/4 HP (58704-XXXX)	69014-001	(Parts 7, 8 & 18a)
	1 HP (58703-XXXX)	69015-001	(Parts 7, 8 & 18b)
	1-1/2 HP (58702-XXXX)	69016-001	(Parts 7, 8 & 18c)
	2 HP (58701-XXXX)	69017-001	(Parts 7, 8 & 18d)
	3 HP (58700-XXXX)	69018-001	(Parts 7, 8 & 18e)
	3/4 HP 2 Speed (59919-XXXX)	66314-001	(Parts 7, 8 & 18J)
	1 HP 2 Speed (59920-XXXX)	66315-001	(Parts 7, 8 & 18I)
	1.5 HP 2 Speed (59921-XXXX)	66316-001	(Parts 7, 8 & 18H)
	2 HP 2 Speed (59922-XXXX)	66317-001	(Parts 7, 8 & 18G)
	1 HP Variable Speed (59923-XXXX)	66318-001	(Parts 7, 8 & 18F)
	2.4 HP Variable Speed (59927-XXXX)	66319-001	(Parts 7, 8 & 18K)
	3.45 HP Variable Speed (59925-XXXX)	66320-001	(Parts 7, 8 & 18L)
	Impeller Kit		
	3/4 HP (58704-XXXX, 59919-XXXX, 59923-XXXX)	69019-001	(Parts 4, 7, 16a & 19)
	1 HP (58703-XXXX, 59920-XXXX)	69020-001	(Parts 4, 7, 16b & 19)
	1-1/2 HP (58702-XXXX, 59921-XXXX, 59927-XXXX)	69021-001	(Parts 4, 7, 16c & 19)
	2 HP (58701-XXXX, 59922-XXXX, 59925-XXXXXX)	69022-001	(Parts 4, 7, 16d & 19)
	3 HP (58700-XXXX)	69023-001	(Parts 4, 7, 16e & 19)
	Diffuser Kit		
	3/4 HP (58704-XXXX, 59919-XXXX, 59923-XXXX)	69025-001	(Parts 5, 7 & 17a)
	1, 1-1/2, 2 HP (58703-XXXX, 58702-XXXX, 58701-XXXX, 59920-XXXX, 59921-XXXX, & 59922-XXXX)	69024-001	(Parts 5, 7 & 17b)
	3 HP (58700-XXXX)	69026-001	(Parts 5, 7 & 17c)
	Wet End Kits		
	3/4 HP (58704-XXXX)	69133-001	(Parts 18a,16a,17a,1,3,4,5,7,8a,8b,12,19,22)
	1 HP (58703-XXXX)	69132-001	(Parts 18b,16b,17b,1,3,4,5,7,8a,8b,12,19,22)
	1-1/2 HP (58702-XXXX)	69131-001	(Parts 18c,16c,17b,1,3,4,5,7,8a,8b,12,19,22)
	2 HP (58701-XXXX)	69130-001	(Parts 18d,16d,17b,1,3,4,5,7,8a,8b,12,19,22)
	3 HP (58700-XXXX)	69129-001	(Parts 18e,16e,17c,1,3,4,5,7,8a,8b,12,19,22)
	3/4HP 2 Speed (59919-XXXX)	66332-001	(Parts 18J, 16a, 17a, 1, 3, 4, 5, 7,8a, 8b, 12, 19 & 22)
	1 HP 2 Speed (59920-XXXX)	66331-001	(Parts 18I, 16b, 17b, 1, 3, 4, 5, 7,8a, 8b, 12, 19 & 22)
	1.5 HP 2 Speed (59921-XXXX)	66330-001	(Parts 18H, 16c, 17b, 1, 3, 4, 5, 7,8a, 8b, 12, 19 & 22)
	2 HP 2 Speed (59922-XXXX)	66329-001	(Parts 18G, 16d, 17b, 1, 3, 4, 5, 7,8a, 8b, 12, 19 & 22)
	1 HP Variable Speed (59923-XXXX) 2.4	66328-001	(Parts 18F, 16a, 17a, 1, 3, 4, 5, 7,8a, 8b, 12, 19 & 22)
	HP Variable Speed (59927-XXXX) 3.4	66333-001	(Parts 18k,16c,17b,1,3,4,5,7,8a,8b,12,19,22)
	HP Variable Speed (59925-XXXX)	66334-001	(Parts 18L,16d,17b,1,3,4,5,7,8a,8b,12,19,22)
	Seal Plate Kit	69027-001	(Parts 7, 8 & 12)

Limited Warranty

For three (3) years from the date of purchase, the manufacturer will repair or replace, at its option, for the original owner any parts of its pumps ("Product") which are found upon examination by the manufacturer to be defective in materials or workmanship.

Please call the manufacture at 1-877-278-2797 for instructions. Be prepared to provide a receipt, the model number and serial number when exercising this limited warranty.

Purchaser must pay all labor and transportation charges on Products or parts submitted for repair or replacement.

All non-warranty service charges are the responsibility of the original owner. Failure to pay for non-warranty service charges will void this Limited Warranty.

This Limited Warranty does not cover Products that have been damaged as a result of accident, freezing, abuse, misuse, neglect, improper installation, improper maintenance or failure to operate in accordance with the manufacturer's written instructions. All maintenance and service must be performed by service agents approved by the manufacturer. Any unauthorized alteration or repairs will void this Limited Warranty.

THERE IS NO OTHER EXPRESS WARRANTY. IMPLIED WARRANTIES, INCLUDING THOSE OF MERCHANTABILITY AND FITNESS FOR A PARTICULAR PURPOSE, ARE LIMITED TO ONE (1) YEAR FROM THE DATE OF PURCHASE. THIS IS THE EXCLUSIVE REMEDY AND ANY LIABILITY FOR ANY AND ALL INDIRECT OR CONSEQUENTIAL DAMAGES OR EXPENSES WHATSOEVER IS EXCLUDED.

Some states do not allow limitations on how long an implied warranty lasts, or do not allow the exclusions or limitations of incidental or consequential damages, so the above limitations might not apply to you. This limited warranty gives you specific legal rights, and you may also have other legal rights which vary from state to state.

In no event, whether as a result of breach of contract warranty, tort (including negligence) or otherwise, shall the manufacturer or its suppliers be liable for any special, consequential, incidental or penal damages including, but not limited to loss of profit or revenues, loss of use of the products or any associated equipment, damage to associated equipment, cost of capital, cost of substitute products, facilities, services or replacement power, downtime costs, or claims of buyer's customers for such damages.

This Limited Warranty does not include freight charges for equipment or component parts, to and from the factory, services such as maintenance or inspection, repair or damage due to negligence such as freezing conditions, incorrect installation, nor acts of God. The liability of the manufacturer shall not exceed the repair or replacement of defective parts under this Limited Warranty. This Limited Warranty also does not include unnecessary service calls due to erroneous operational reports, external valve positions, or electrical service. If a non-warranty service call is made, and the homeowner is unwilling to pay for the service call, this Limited Warranty will be voided. This Limited Warranty is voided if the product is repaired or altered by any persons or agencies other than those authorized by the manufacturer. This Limited warranty applies only within the continental USA. For warranty outside the continental USA, contact the manufacturer.

You **MUST** retain your purchase receipt along with this form. In the event you need to exercise a warranty claim, you **MUST** present a **copy** of the purchase receipt at the time of service. Please call the manufacturer at 1-877-278-2797 for service or return authorization and instructions.

DO NOT MAIL THIS FORM TO THE MANUFACTURER. Use this form only to maintain your records.

MODEL NO. _____ SERIAL NO. _____ INSTALLATION DATE _____

V-Green[®] 165

VARIABLE SPEED USER MANUAL

Premium Efficiency Variable Speed Motor



A Regal Brand

COPYRIGHT

Copyright 2013, Regal Beloit America, Inc.
Tipp City, Ohio. All rights reserved.

TRADEMARKS

All trademarks and registered trademarks® are the property of their respective companies. The information in this document incorporates proprietary rights and is not to be duplicated wholly or in part without the express written permission of Regal Beloit Corporation and / or Regal Beloit America, Inc.

June 2013/USA

Table of Contents

Safety	2
1. Introduction	3
2. Navigation Overview	3
3. Quick Start Instruction	5
3.1 Quick Start Guide (Using Factory Default Schedule)	5
3.2 Quick Start Guide (User Defined Custom Schedule)	6
4. Overview	8
5. Wiring	9
6. User Interface Operation	12
6.1 LED and Function Overview	12
6.2 User Interface Key Pad Overview	13
6.3 Set the Schedule	13
6.4 Running V-Green 165 from Key Pad	15
6.5 OVERRIDE	17
6.6 Schedule Advance	18
6.7 Key Lockout	20
6.8 Motor Pause	21
6.9 Temporary Stop with Digital / Serial Input	21
6.10 Reset Factory Defaults	22
7. Priming	22
8. Freeze Protection	22
9. Control with Digital Inputs	23
10. DIP Switches	24
11. Care and Maintenance	25
12. FAULT Status	25
13. Specifications	27
14. Troubleshooting Guide	28

SAFETY

Safety is emphasized throughout this user manual. These are safety alert symbols and signal words. They alert the user to potential personal injury hazards. Obey all safety messages to avoid possible injury or death or damage to equipment and other property.

DANGER



DANGER indicates a hazardous situation which, if not avoided, will result in death or serious injury.

WARNING



WARNING indicates a hazardous situation which, if not avoided, could result in death or serious injury.

CAUTION



CAUTION indicates a hazardous situation which, if not avoided, could result in minor or moderate injury.

NOTICE



NOTICE identifies potential equipment damage or failure conditions and alerts personnel to potentially dangerous situations.

1 Introduction

The V-Green® 165 is a premium efficiency variable speed motor that provides tremendous program flexibility in terms of motor speed and time settings. The variable speed V-Green 165 is intended to enable running at the lowest speeds needed to maintain a sanitary environment, which in turn minimizes energy consumption. Pool size, the presence of additional water features, chemicals used to maintain sanitary conditions, and environmental factors will impact optimal programming necessary to maximize energy conservation.

⚠ WARNING

The V-Green 165 is for use with 208-230 Vrms nominal, and in pool pump applications ONLY. Connection to the wrong voltage, or use in other application may cause damage to equipment or personal injury.

The integrated electronics interface controls the speed settings as well as the run durations. The V-Green 165 can run at speeds ranging between 600 and 3450 RPM and is rated for 208-230 Vrms at an input frequency of 60 Hz.

2 Navigation Overview

- +, - Increases/decreases selected value
- Pressing any key following a change accepts the current value displayed inside the setting

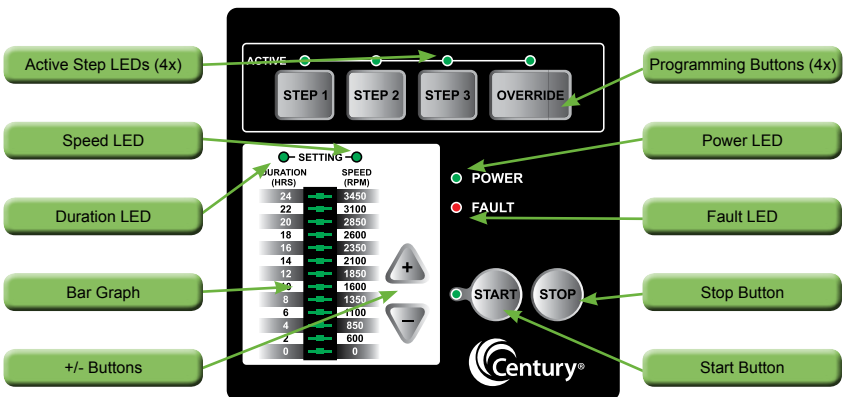

Figure 1: V-Green 165 User Interface Button Descriptions

 CAUTION

If power is connected to the V-Green 165 motor, pressing any of the following buttons referred to in section 2 could result in the motor starting. Failure to recognize this could result in personal injury or damage to equipment.

Note: The START button must be pressed for the V-Green 165 to operate. The START LED will illuminate after the button has been pressed indicating the V-Green 165 is capable of operating. Pressing the stop button will turn off the START LED and stop the motor if running.

V-Green 165 Features

- Simple user interface
- Digital inputs for compatibility with pool automation systems
- Motor design reduces noise emissions
- UV and rain-proof enclosure
- Freeze Protection
- Manual OVERRIDE
- Compatibility w/ V-Green 270 user interface
(sold as a separate accessory)
- High efficiency electromechanical motor and control design

Benefits of adding an optional V-Green 270 user interface with the V-Green 165 motor

- Ability to conduct field troubleshooting (i.e., view FAULT codes and real time operating parameters).
- Ability to set a pump running schedule based on a real clock setting (i.e., must input actual time which then determines pump start and stop times).
- Ability to remotely mount the V-Green 270 user interface (provides easy access of user interface depending on pump location).
- Ability to configure **prime speed** and **prime duration**.

- Ability to configure **freeze protection** temperature.
- Ability to view actual speed and power of the V-Green 165 in real time.
- Ability to adjust the V-Green 165 motor speed in 25 RPM increments (to fine tune flow for certain pool installations).
- Battery backup to store time setting.

3 Quick Start Instruction

⚠ CAUTION

If power is connected to the V-Green 165 motor, pressing any of the following buttons referred to in section 3 could result in the motor starting. Failure to recognize this could result in personal injury or damage to equipment.

3.1 Quick Start Guide (Using the factory default schedule)

The following table describes the factory default settings for DURATION and SPEED order:

Button	Duration (In Hours)	Speed (In RPM)
STEP 1	4	3100
STEP 2	4	2600
STEP 3	8	1600
OVERRIDE	2	3450

Pressing the START key will start the V-Green 165 based on the factory default schedule.

NOTE: If power is cycled to the V-Green 165 and the user does not press the STOP key, the V-Green 165 will **automatically** start and run the programmed default schedule shown in the chart above. This feature ensures that the V-Green 165 will re-start in the event of a power outage.

3.2 Quick Start Guide (User-defined custom schedule)

A V-Green 165 user can set the program DURATION and SPEED for STEP 1, STEP 2, STEP 3 & OVERRIDE keys.

NOTE: V-Green 165 must be **Stopped (Press STOP Key)** for programming DURATION and SPEED of the STEP 1, STEP 2, and STEP 3 keys. OVERRIDE DURATION and SPEED can be programmed when the V-Green 165 is **either** stopped or running.

Press the STEP 1 key. The STEP 1 button and DURATION setting LEDs will illuminate. The bar graph will show default DURATION for STEP 1.

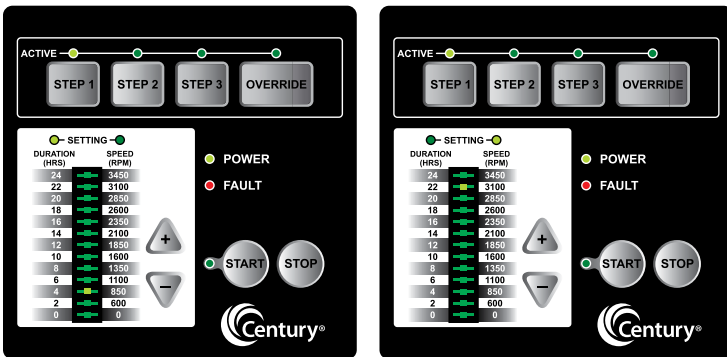

1. Press UP (+) or DOWN (-) arrows to change the DURATION
2. Press the STEP 1 key again to change the SPEED setting. The SPEED setting LED will illuminate. The bar graph will show default SPEED for STEP 1.
3. Press UP (+) or DOWN (-) arrows to change the SPEED.
4. Press any STEP or OVERRIDE key to save the DURATION and SPEED settings for STEP 1. If the user decides not to save the settings, pressing the STOP key will revert back to the previously stored setting.

5. Press STEP 2, STEP 3, or OVERRIDE key. Repeat steps 1- 4 to program the corresponding DURATION and SPEED for each button.
6. Press START to run the V-Green 165 based on the programmed 24 hour schedule.
7. Pressing the STOP button will stop the V-Green 165.

NOTE: The V-Green 165 can only be set to operate on a 24-hour schedule. If a user attempts to program a schedule with a combined duration for all three steps greater than 24 hours, the V-Green 165 software will retain the current STEP time duration only, and will zero out the other two STEP time settings. As an example, if STEP 1 equals eight (8) hours, STEP 2 equals nine (9) hours, and STEP 3 equals eight (8) hours – for a combined 25 hours – the V-Green 165 will retain the setting for the current Step being programmed and zero out the remaining two. For details regarding the set-up of the three steps as part of a 24-hour schedule, see section 6.

4 Overview

NOTICE

The V-Green 165 can and should be optimized to suit individual pool conditions. Specific conditions including pool size, other devices, features, and environmental factors can all impact the optimal settings.

Program customization may require some trial-and-error to determine the most satisfactory settings as dictated by the conditions. In all cases, setting the V-Green 165 at the lowest speed for the longest duration is the best strategy to minimize energy consumption. However, conditions may require running the V-Green 165 at a higher speed for some duration of time each day to maintain proper filtration to achieve satisfactory sanitation.

The User Interface is located on top of the V-Green 165. To the right of the STEP buttons is the OVERRIDE button. This button can be used to operate the V-Green 165 at speeds outside of the normal operating schedule.

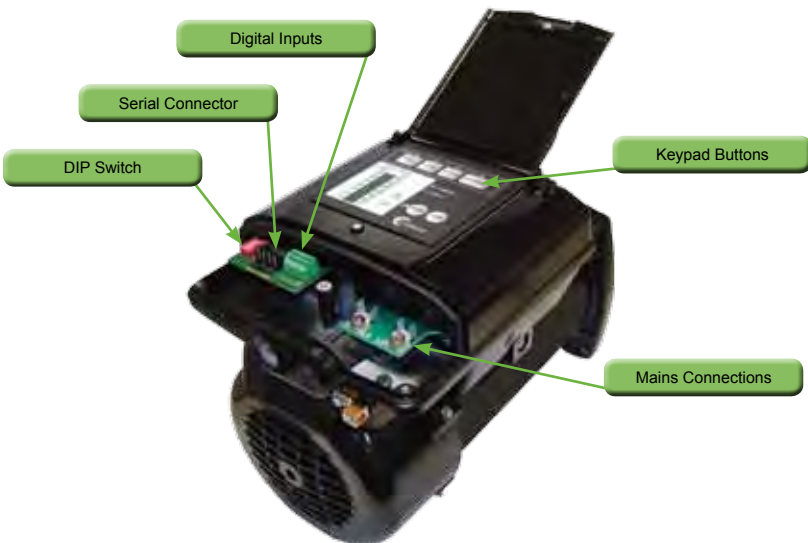

Figure 2: V-Green 165 Overview

5 Wiring

⚠ WARNING

The V-Green 165 controller must be wired according to the locally adopted version of the NEC. A licensed, qualified electrician should complete the wiring for this product. Failure to comply with this may result in death, serious personal injury or property damage.

The V-Green 165 controller must be wired according to the locally adopted version of the NEC. A licensed, qualified electrician should complete the wiring for this product.

The controller is designed to operate with 208-230 Vrms, single phase power.

The V-Green 165 is designed to handle either a bare wire connection or a quick disconnect connection. The quick disconnect tab is 0.250" and will handle any commonly available mating connectors. For a direct wire connection, the wire insulation should be stripped to a length of approximately 0.33." The terminal block is capable of handling solid or stranded wire up to 12 AWG in size. The screw for the mains connections should be properly tightened to a torque value of 10 in-lb.

Pin #	Wire Color	Description
L1	Black	Hot 1
L2	Red or White	Hot 2
Green screw	Green	Earth

Table 1: Mains Connection

Pin #	Wire Color	Description
J201 - 1	Red	+12V
J201 - 2	Black	A
J201 - 3	Yellow	B
J201 - 4	Green	COM

Table 2: Communication Connection

⚠ WARNING

Power should be turned off when installing, servicing, or repairing electrical components. Observe all warning notices posted on the existing equipment, V-Green 165, and in these installation instructions.

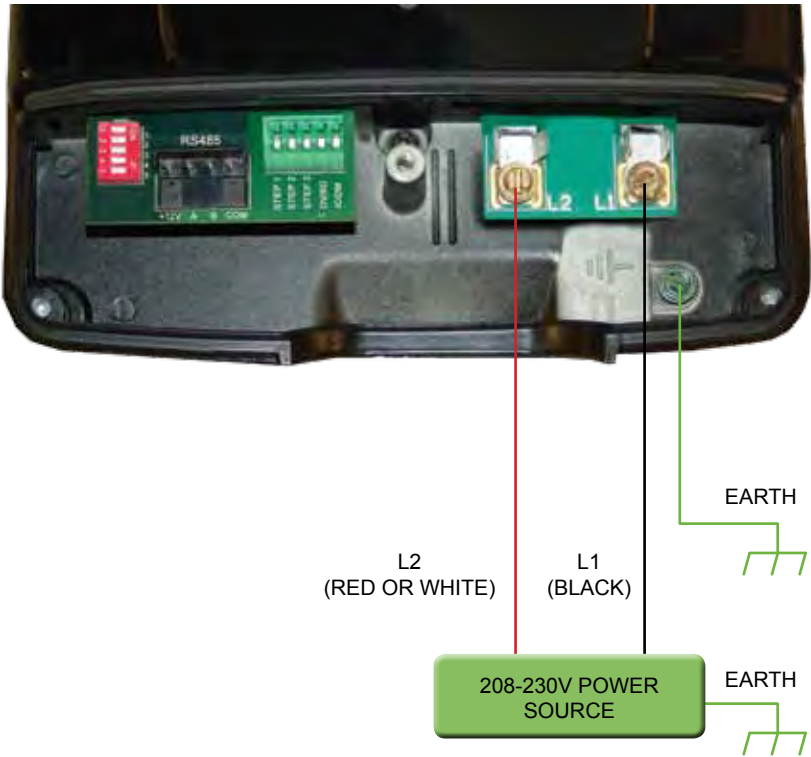

Figure 3: Mains Connection Diagram

V-Green 165 Controller

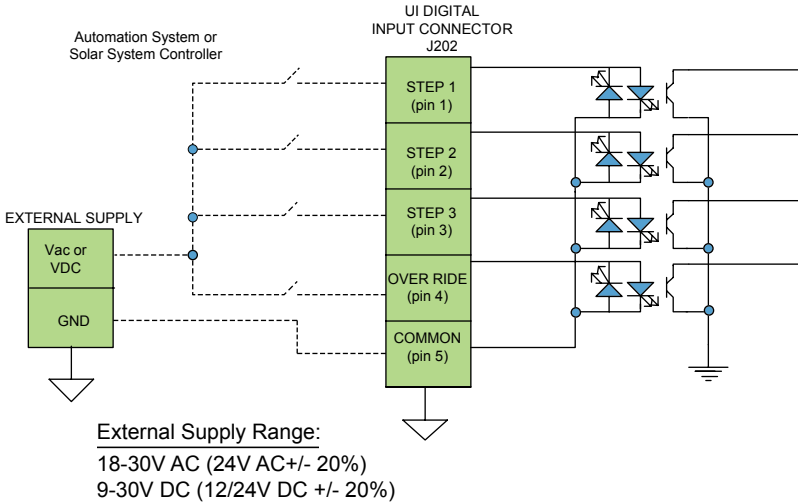

Figure 4: Wiring Diagram for Digital Inputs

⚠ WARNING

Access to these terminals is in close proximity to the mains connectors which carry line voltage capable of causing personal injury or damaging the equipment if contact is made. Power should be turned off when accessing this area.



Figure 5: Digital Input connector

6 User Interface Operation

6.1 LED and Function Overview

Key for LEDs										
X	Solid ON Indication									
*	Blinking @ 1 sec									
**	Alternates between DURATION and SPEED									
#	Blink for three times @ 1 sec									

LED → Function ↓	Power	START	FAULT	STEP1	STEP2	STEP3	OVERRIDE	SPEED SETTING	DURATION SETTING	BARGRAPH
Power On	X									
Keypad Functions										
Step1	X	X		X				**	**	**
Step2	X	X			X			**	**	**
Step3	X	X				X		**	**	**
Override	X	X					X	**	**	**
Keypad lock	X			*	*	*				
Keypad Unlock	X			X	X	X				
Schedule Advance	X	*							X	X
Restore Default settings	X									# (All LED)
Motor pause	X	*					*	X		X
Temporary stop	X									* (0 RPM)
Digital Input Functions										
DI1 ON	X			*				X		X
DI2 ON	X				*			X		X
DI3 ON	X					*		X		X
DI4 ON	X						*	X		X
Serial Communication Functions										
Serial Communication	X							*		
Motor spinning	X							*		X
Freeze Protection										
Freeze Protection	X								*	X
Fault Handling										
UI fault	X		*							
Controller fault	X		X							

Figure 6: LED Functionality Table

6.2 User Interface Key Pad Overview

⚠ CAUTION

If power is connected to the V-Green 165 motor, pressing any of the following buttons referred to in this section 6.2 could result in the motor starting. Failure to recognize this could result in personal injury or damage to equipment.

1. **STEP 1 (Set Schedule)** → DURATION and SPEED
2. **STEP 2 (Set Schedule)** → DURATION and SPEED
3. **STEP 3 (Set Schedule)** → DURATION and SPEED
4. **OVERRIDE (Settings)** → DURATION and SPEED
5. **START**
6. **STOP**

6.3 Set the Schedule

⚠ CAUTION

If power is connected to the V-Green 165 motor, pressing any of the following buttons referred to in this section 6.3 could result in the motor starting. Failure to recognize this could result in personal injury or damage to equipment.

Set the DURATION and SPEED for the V-Green 165 using the keys on the User Interface. The schedule is based on a 24-hour schedule and will repeat each day of the week.

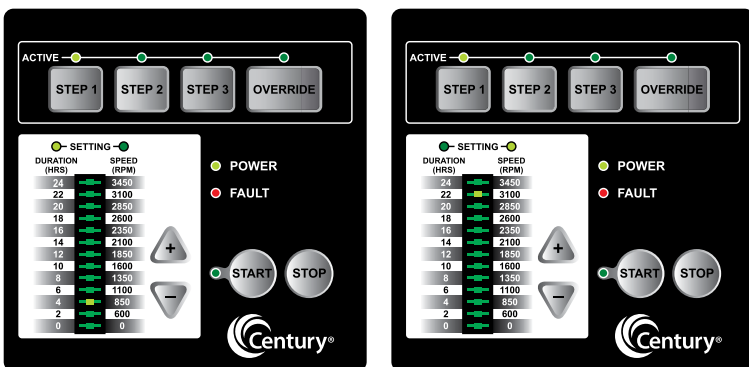

The highest speed rating for the V-Green 165 is 3450 RPM and the lowest is 600 RPM. Unless a new user-defined schedule is entered, the V-Green 165 will operate based on the following factory default schedule:

Button	Duration (In Hours)	Speed (In RPM)
STEP 1	4	3100
STEP 2	4	2600
STEP 3	8	1600
OVERRIDE	2	3450

Table 3: Factory default schedule

Schedule Tables

Use the tables below to record a personalized operating schedule. Recording the planned schedule in the table below will make the programming process easier and will help the user remember the custom settings in case of inadvertent loss of schedule. The user interface will not allow the user to program an overlap between different STEPs of the schedule. The STEP currently being set will always take priority over any previous settings. In the event a user attempts to program with a combined duration greater than 24 hours, the current STEP setting will be retained whereas the other two STEP settings will be cleared to zero hours requiring the user to reset them. Prior to beginning the actual programming process, it is advisable for the user to review the planned schedule as outlined in chart form to ensure the cumulative duration is not greater than 24 hours and no overlaps exist. It is always a good idea to double check your programmed settings for accuracy once you have completed the programming process.

Setup #1			
	Step 1	Step 2	Step 3
Duration			
Speed			

Setup #2			
	Step 1	Step 2	Step 3
Duration			
Speed			

Table 4: Custom Schedule

6.4 Running V-Green 165 from Keypad

⚠ CAUTION

If power is connected to the V-Green 165 motor, pressing any of the following buttons referred to in this section 6.4 could result in the motor starting. Failure to recognize this could result in personal injury or damage to equipment.

1. Press the START key and the V-Green 165 will run the programmed 24 hour duration schedule. The START event will be stored in the controller. Should a power outage occur, the V-Green 165 will automatically re-start at STEP 1 when power is restored.
2. The V-Green 165 will always run the PRIMING sequence when it starts from the OFF state, including when it automatically restarts following a power outage. The default Prime setting is defined in the “Priming” section of this document.
3. The V-Green 165 then starts running in STEP 1 at the programmed DURATION and SPEED. The “ACTIVE LED” for STEP 1 will turn ON. The DURATION and SPEED setting LEDs along with the respective bar graph LED will blink back and forth every three (3) seconds.

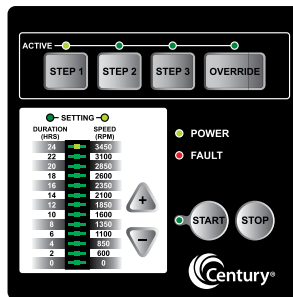
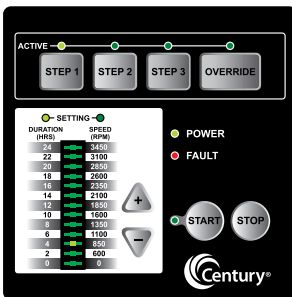

4. This sequence will then repeat for STEP 2 and then STEP 3 without the V-Green 165 stopping.
5. At the end of STEP 3, the V-Green 165 will wait if necessary for the completion of the 24-hour schedule. During this waiting period (if applicable), all of the “active step LEDs” will remain OFF. However, the START LED will still be illuminated. After completion of the 24 hour schedule, the system restarts at STEP 1 and this cycle will repeat indefinitely until the user presses the STOP key.

NOTE: Pressing a STEP key other than for the STEP currently running will cause an immediate transition to the newly selected STEP. The V-Green 165 will continue with the programmed schedule from that point forward.

NOTE: If STOP is pressed during normal schedule operation, the 24 hour schedule will stop. When START is pressed again, the 24 hour schedule will start from STEP 1.

NOTE: If power is lost while the V-Green 165 is running a 24 hour schedule, upon restoration of power the V-Green 165 will start the 24 hour schedule from STEP 1.

NOTE: If a digital input (provided from an external source) is detected, the V-Green 165 will start running on the STEP 1, STEP 2, STEP 3, or OVERRIDE speed corresponding to the digital input. Upon removing the digital input (provided from an external source), the V-Green 165 will stop and the user will need to press START to begin the 24 hour schedule operation. However, if START was already pressed prior to receiving a digital input, then the V-Green 165 will resume running the 24 hour schedule once the digital input is removed.

NOTE: Pressing STOP at any time turns the V-Green 165 OFF and clears the start time for the 24 hour schedule.

6.5 OVERRIDE

The V-Green 165 is equipped with an OVERRIDE feature, which can be engaged to temporarily run at higher or lower speeds ranging between 600 to 3450 RPM. Once the OVERRIDE duration has elapsed, the V-Green 165 will automatically return to the programmed schedule.

1. Pressing the OVERRIDE key while the V-Green 165 is running will cause the V-Green 165 to start running in the OVERRIDE mode at the programmed DURATION and SPEED. The “active LED” for OVERRIDE will illuminate. The DURATION and SPEED setting LEDs along with its respective bar graph LED will blink back and forth at three (3) second intervals.
2. The UP (+) / DOWN (-) arrows allow the user to configure OVERRIDE DURATION and SPEED. These settings can be changed while the V-Green 165 is running. These settings are stored each time the UP (+) / DOWN (-) arrows are pressed.

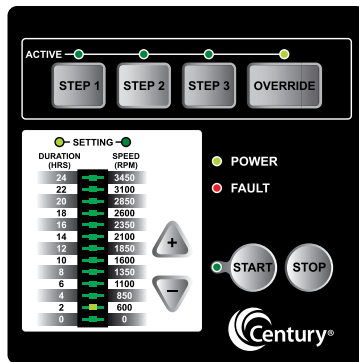

NOTE: When the OVERRIDE duration ends, the V-Green 165 resumes the 24 hour schedule at the point in the currently programmed 24 hour schedule where it normally would be running at that time. The OVERRIDE duration will not affect the start or stop times of the 24 hour schedule. For example, if OVERRIDE runs during a period overlapping with a later part of STEP 1 and an early part of STEP 2, the start time of STEP 3 is not affected.

NOTE: Pressing/Holding OVERRIDE key for more than three (3) seconds will cancel OVERRIDE mode.

NOTE: During the OVERRIDE mode, the V-Green 165 will not start with the priming sequence.

NOTE: It is recommended that you do not set the OVERRIDE duration to 0 HRS. Setting the OVERRIDE duration to 0 HRS will not allow you to change the duration setting while the motor is running. The motor will have to be stopped in order to change the OVERRIDE settings if the duration is set to 0 HRS.

6.6 Schedule Advance

⚠ DANGER

Do not perform any maintenance on the motor while the motor is in Schedule Advance Mode. The motor may start without warning. This event could cause death or serious personal injury.

The Schedule Advance mode allows the user to press the START button at one time of the day, with the 24-hour schedule starting at a different time of day. The V-Green 165 can run in the Schedule Advance mode (by using the OVERRIDE button) and upon completion will begin the programmed 24 hour schedule at STEP 1 DURATION and SPEED.

The following steps should be followed to set Schedule Advance mode:

1. With the V-Green 165 stopped, press and hold the START key for more than three (3) seconds. The START LED will blink at a rate of one second per pulse. The DURATION setting LED and respective bar graph LED will remain turned ON until the Schedule Advance mode is complete.

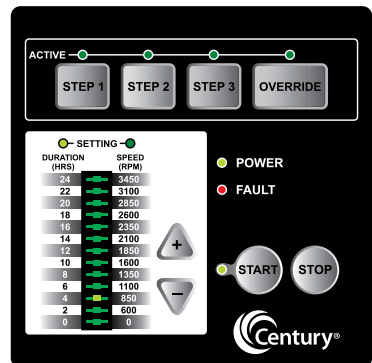

2. Press the UP (+) or DOWN (-) arrows to set the desired delay time after which the 24-hour schedule should start. The Schedule Advance mode will automatically start after the desired delay time is selected. The Schedule Advance mode can be canceled by pressing the STOP key.

NOTE: The OVERRIDE button will still function when the Schedule Advance mode is active. This will allow the user to run the V-Green 165 during the period of the Schedule Advance mode.

NOTE: While the V-Green 165 is in the Schedule Advance mode, if a user presses STEP 1, STEP 2, STEP 3 or the START key, the system will start the normal schedule and the Schedule Advance mode will be canceled.

NOTE: While the V-Green 165 is in the Schedule Advance mode, if a user presses the STOP key, then the Schedule Advance mode is canceled.

NOTE: If power is lost while the V-Green 165 is in the Schedule Advance mode, then the 24-hour schedule will automatically start when power is restored.

6.7 Key Lockout

⚠ CAUTION

Key lockout will not prevent the motor from being stopped by pressing the STOP button. If the motor is operating in “key lockout” mode, and being controlled through a digital or serial input, the motor will only temporarily stop (4 min.) it will then restart.

The V-Green 165 user interface has a “key lockout” feature to prevent unwanted changes to the settings.

To lock the keys, hold down the “STEP 1, STEP 2, and STEP 3” buttons all at the same time for at least three seconds. The “active LEDs” for STEP 1, STEP 2, and STEP 3 will blink for 30 seconds indicating that the keypad is locked.

The user can unlock the keys by holding down the same three STEP buttons for at least three seconds. The “active LEDs” for STEP 1, STEP 2, and STEP 3 will illuminate temporarily indicating the keypad is unlocked.

NOTE: While operating in “key lockout” mode the motor can still be stopped by pressing the stop key. If no digital or serial input is present the motor will remain stopped. If the motor is being controlled by a digital or serial input the motor will only temporarily stop for 4 minutes. See section 6.9 for more information on temporary stop.

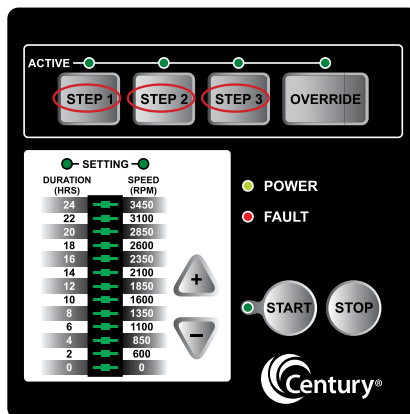

6.8 Motor Pause

The V-Green 165 user interface has a “motor pause” feature that will allow the user to temporarily stop the V-Green 165 for maintenance work without disrupting the 24 hour schedule (i.e., for backwashing the filter). If the V-Green 165 is currently running, the user can press and hold the START button for more than three (3) seconds and the V-Green 165 will stop and remain off until the user presses and holds the START button again for more than three (3) seconds. The START and OVERRIDE buttons will blink once every second indicating that the “motor pause” feature is enabled. These LEDs will stop blinking once this feature is canceled.

6.9 Temporary Stop with Digital / Serial Input

 CAUTION

Temporary stop functionality only works while the V-Green 165 is being controlled by a digital or serial input. If the motor is being controlled by the integrated key pad and STOP is pressed, the motor will stop and remain stopped.

The V-Green 165 has a “temporary stop” feature that will immediately stop the V-Green 165 when being controlled by a serial or digital input. The user can press the STOP button while the V-Green 165 is running and the V-Green 165 will stop and stay off for four (4) minutes. Once this time has elapsed, the V-Green 165 will return to normal operation and accept an input from digital or serial input source. Refer to section 9 for additional details on digital inputs.

NOTE: If the V-Green 165 is operating from serial or digital input, the ‘0 RPM’ LED of the bar graph will blink once every second indicating the “temporary stop” feature has been activated. After the specified time period, the V-Green 165 will return to normal operation and accept an input from any digital or serial input source. Refer to section 9 for additional details on digital inputs.

6.10 Reset Factory Defaults

The V-Green 165 user interface has a “Reset to Factory Defaults” feature to restore the schedule settings back to the original values programmed at the factory. The user must press and hold the STOP and OVERRIDE buttons for three (3) seconds to reset the settings back to factory defaults. All of the UI bar graph LED’s will flash three (3) times to confirm the settings were restored to factory defaults.

7 Priming

The V-Green 165 will always run the PRIMING sequence when starting from the OFF state, except when starting in OVERRIDE. The factory Prime settings are 2600 RPM for three (3) minutes.

8 Freeze Protection

NOTICE

The freeze protection function will NOT operate if the START button is not pressed. This can be confirmed by verifying that the START LED is illuminated.

In the event that the outside air temperature drops below a set threshold, the V-Green 165 will automatically turn on (assuming the START button has been pressed) and circulate the pool water. The Freeze Protection will run according to the following conditions (utilizing the factory default settings):

Freeze Protection turn ON temperature = 39°F

Freeze Protection Duration = 8 Hours

By utilizing the V-Green 270 user interface (accessory sold separately) these factory default settings can be changed.

Once this eight (8) hour period has elapsed, the V-Green 165 will check the ambient temperature again. If the temperature is still below the set threshold, the V-Green 165 will run for an additional 8 hours. If the temperature is above the threshold, the V-Green 165 will automatically return to the 24-hour based schedule.

9 Control with Digital Inputs

The user can run the V-Green 165 at the programmed STEP 1, STEP 2, STEP 3, or OVERRIDE speeds by utilizing the four digital inputs. STEP 1, STEP 2, STEP 3, or OVERRIDE are equivalent to Digital Input 1, 2, 3 or 4 respectively.

NOTE: The controller is rated to accept digital inputs of 18V-30V AC (24V AC +/- 20%) and 9-30V DC (12/24V DC +/- 20%).

NOTE: The V-Green 165 will detect either a 50/60Hz for AC input or an active low signal for DC digital inputs.

The items below describe the functionality of the digital inputs:

1. If the user provides any one of the 4 digital inputs, then the corresponding ACTIVE STEP LED will blink every one (1) second. The SPEED LED and corresponding bar graph LED will be illuminated to indicate the Digital Input is functioning properly.
2. The START LED will be OFF when a digital input is present.

 **WARNING**

Access to these terminals is in close proximity to the mains connectors which carry line voltage capable of causing personal injury or damaging the equipment if contact is made. Power should be turned off when accessing this area.

NOTE: A generic wiring diagram is provided in figure 7 for connecting the V-Green 165 to a “System Level Controller”. This concept can be applied to a solar system or any other type of control system.

NOTE: There is no schedule for digital inputs. The timing for each speed is controlled directly by the digital inputs.

NOTE: The digital inputs have the highest priority amongst all the inputs (i.e., keypad, serial, or digital). Therefore the serial commands as well as the User Interface inputs will be ignored when a digital input is present.

NOTE: If more than one digital input (switch) is present, then the V-Green 165 will give priority to the highest number digital input. Therefore OVERRIDE has highest priority followed by STEP 3, then STEP 2, then STEP 1.

NOTE: If no digital input is detected, the V-Green 165 will automatically start the 24 hour schedule if the START key was pressed prior to the application of a digital input.

⚠ WARNING

Access to these terminals is in close proximity to the mains connectors which carry line voltage capable of causing personal injury or damaging the equipment if contact is made. Power should be turned off when accessing this area.

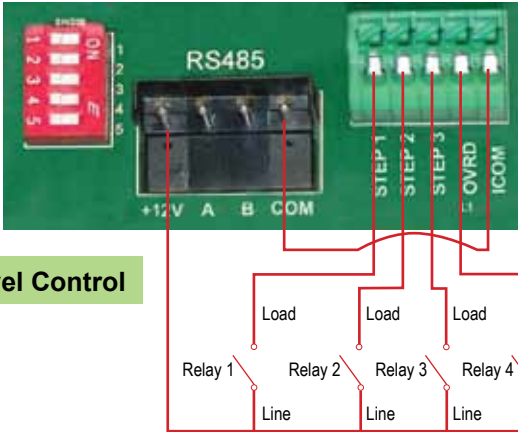

System Level Control

Figure 7: System Level Control Wiring Diagram

10 DIP Switches

⚠ WARNING

Access to these terminals is in close proximity to the mains connectors which carry line voltage capable of causing personal injury or damaging the equipment if contact is made. Power should be turned off when accessing this area.

The DIP switches can be used to configure different settings for the V-Green 165. Each DIP switch and their corresponding function is defined in Table 5.

Switch #	Function
1	Power output on/off
2	Not Used
3	Not Used
4	Not Used
5	Not Used

Table 5: DIP Switch Functions



Figure 8: DIP Switches

11 Care and Maintenance

The V-Green 165 is both reliable and robust in harsh environments. However, this product does contain electronics that are cooled by a fan mounted to the V-Green 165. In order to ensure optimum reliability of this product, it is recommended to clean the fan inlet on the back of the V-Green 165 once a month. It is also important to keep this area free of large debris such as leaves, branches, mulch, plastic bags, etc.

12 FAULT Status

⚠ WARNING

While the FAULT LED is illuminated the motor will not run, upon clearing the fault, the motor may automatically resume running depending on where in the schedule the FAULT occurred. This may cause personal injury or damage to the equipment.

The paragraphs below illustrate the possible faults that can occur with the V-Green 165. If the V-Green 165 does not restart automatically following the FAULT, cycle ac power to the V-Green 165 and wait five (5) minutes. If this does not correct the situation, please contact Customer Service at 1-800-262-6484.

The V-Green 165 reads the FAULT status and provides feedback to the user via the FAULT LED. The V-Green 165 will illuminate the FAULT LED when a FAULT is present. The V-Green 165 will stop and remain OFF when the FAULT is present. Once the FAULT is cleared, if the V-Green 165 was previously running, it will automatically resume running the normal schedule.

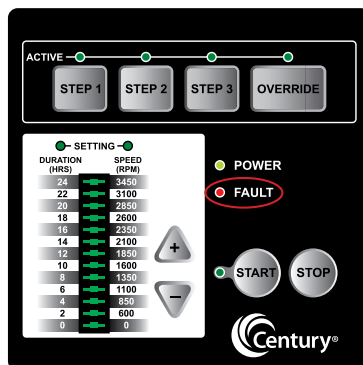

Below is the behavior of the FAULT LED when a FAULT is detected:

1. When a FAULT is present, and the motor is **not** running, only the FAULT LED and power LED will illuminate.
2. When a FAULT is present, and the motor is running, then the FAULT LED will illuminate. During the FAULT condition, the bar graph LEDs on the interface will turn OFF. However, the power LED, start LED & active STEP LED will remain illuminated.
3. When a FAULT is present and the FAULT LED is illuminated, only the STOP key will function. The remaining buttons become disabled.
4. When the FAULT LED is continuously ON (i.e. not blinking), a FAULT is present in the controller. When the FAULT LED is blinking every one (1) second, a FAULT is present in the user interface.
5. When the FAULT has cleared, the FAULT LED will turn OFF.
6. Once the FAULT is cleared, if the V-Green 165 was previously running, it will **automatically** resume running the normal schedule.

Please see Section 14 for troubleshooting issues and their resolutions.

13 Specifications

Overall Ratings

Input Voltage	208 - 230 Vrms nominal	
Input Current	10.5 - 10.0 Arms	
Input Frequency	Single phase, 60 Hz	
Control Terminals	18-30V AC (24V AC +/- 20%) or 9-30V DC (12/24V DC +/- 20%)	
Auxiliary Load Terminals	N/A	
Maximum Continuous Load	1.65 THP (Total Horse Power)	
Speed Range	600 - 3450 RPM	
Environmental Rating	NEMA Type 3R	
Agency Approval	R/C XDNW2.E302804 R/C XDNW8.E302804	
Ambient Conditions		
	Storage	-40°C to +85°C (-40°F to +185°)
	Operating	0°C to +50°C (+32°F to +122°F)
	Humidity	Relative 0 to 95 % non-condensing



14 Troubleshooting Guide

⚠ WARNING

Diagnosing certain symptoms may require close interaction with, or in close proximity to, components that are energized with electricity. Contact with electricity can cause death, personal injury, or property damage. When trouble shooting the V-Green 165, diagnostics involving electricity should be cared for by a licensed professional.

Symptom	Possible Causes	Potential Solutions
V-GREEN 165 FAILS TO START	Controller DIP switches not configured properly	Verify that the DIP switches of SW100 under the controller terminal box cover are in the correct position. Refer to section 10.
	Mains Voltage is not present	Replace fuse, reset breaker/GFI.
		Tighten mains wire connections.
	User Interface is not connected	Check connections at J201 connector.
	V-Green 165 shaft is locked	Check if the V-Green 165 can be rotated by hand and remove any blockage.
V-Green 165 shaft is damaged	Replace V-Green 165.	
V-GREEN 165 RUNS THEN STOPS	Over temperature FAULT	Check that back of V-Green 165 is free from dirt and debris. Use compressed air to clean.
	Over current FAULT	V-Green 165 will automatically restart after one (1) minute.
V-GREEN 165 IS NOISY	Debris in contact with fan	Check that back of V-Green 165 is free from dirt and debris. Use compressed air to clean.
	Debris in strainer basket	Clean strainer basket.
	Loose mounting	Check that mounting bolts of V-Green 165 and pump are tight.
V-GREEN 165 RUNS, BUT NO FLOW	Impeller is loose	Check that V-Green 165 is spinning by looking at fan on back of V-Green165. If so, check that pump impeller is correctly installed.
	Air leak	Check plumbing connections and verify they are tight.
	Clogged or restricted plumbing	Check for blockage in strainer or suction side piping.
Checked for blockage in discharge piping including partially closed valve or dirty pool filter.		

Disclaimer

The information in this document incorporates proprietary rights and is not to be duplicated wholly or in part without the express written permission of Regal Beloit America, Inc. © Copyright 2013.

The text and images in this document are not to be modified without express written permission of Regal Beloit Corporation and / or Regal Beloit America, Inc.

Regal Beloit America, Inc.
531 North Fourth Street
Tipp City, OH 45371
Fax: (937) 667-5030

www.centuryelectricmotor.com
Customer Service 1-800-262-6484

Please refer to our website
www.pool-motors.com
for updates to this printed manual.



Distribution Marketing
1325 Heil Quaker Blvd.
LaVergne, TN 37086
Phone: (866) 887-5216
Fax: (800) 468-2062
www.pool-motors.com

A Regal Brand

REGAL